

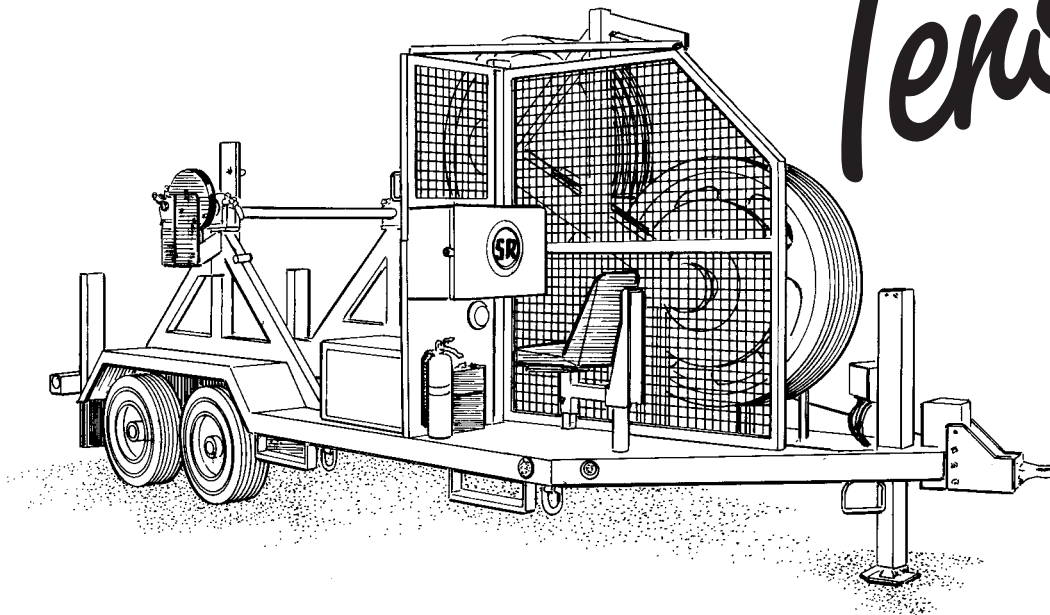

BWT-1545

Tensioner



- Operation
- Service
- Parts

SHERMAN & REILLY, INC.

P.O. Box 11267 • 400 West 33rd Street
Chattanooga, TN 37401 USA

Phone 423•756•5300

Fax No. 423•756•2948

Toll-Free 800•251•7780

Web Site www.sherman-reilly.com

© Copyright February 26, 2010 Sherman & Reilly, Inc.



TABLE OF CONTENTS

Section 1 • INTRODUCTION

Important Information	1.1
Specifications	1.2

Section 2 • SAFETY

Warning Terms	2.1
Operator Safety Precautions	2.1
Employer Safety Requirements	2.3

Section 3 • OPERATION

Description of Operating Controls	3.1
Terms You Need To Know	3.3
Towing	3.5
Set-up to Tension	3.6
Reel Installation/Removal	3.7
Reeving the Bullwheels	3.9
Tensioning	3.11
Hydraulic Retriever (Optional)	3.12
Installing Pulling Grip	3.13
Spider Rewind System (Optional)	3.13

Section 4 • SERVICE

General Service	4.1
Important Information	4.1
Safety Precautions	4.2
Hydraulic System (Optional Power Pack)	4.3
Service Requirements	4.4

Section 5 • PARTS

Bullwheel Assembly	5.1
36" Brake Caliper	5.2
Conductor Keeper Assembly	5.3
Fairlead Roller Assembly	5.4
Reel Shaft Assembly	5.6
Bed Roller Assembly	5.8
16" Payout Brake Assembly	5.9
Hydraulic Payout Brake Assembly	5.10
Spider Rewind Controls (Optional)	5.11
Retriever Drive Assembly – Pilot Line System (Optional)	5.12
Spider Rewind Drive Assembly – Pilot Line System (Optional)	5.14
Spider Guide Roller Assembly – Pilot Line System (Optional)	5.15
Hydraulic Jack Assembly (Optional)	5.16
Operating Controls	5.17
Power Pack Engine & Pump Assembly (Optional)	5.18
Power Pack Components (Optional)	5.19
Trailer Components	5.20
Operator's Seat & Miscellaneous	5.22



IMPORTANT INFORMATION

It is very important to all of us at **Sherman & Reilly** that every machine is operated in a safe manner. We have taken every precaution to guard against the possibility of an accident. To properly, safely operate this machine, it is necessary and important that operators and service people read and understand the information in this and the engine manufacturer's manual. **ANYONE working around the machine should read the safety precautions in the manuals.** Be aware each warning and precaution is to help protect against needless injury. Taking unnecessary risks and ignoring warnings is the primary cause of personal injury and fatal accidents in the work place. If you have any questions regarding operation or safety of a procedure or situation, contact the **Sherman & Reilly** Customer Service Manager at **1-800-251-7780**.

Sherman & Reilly Bullwheel Tensioners utilize precision machined urethane lined grooves, to eliminate differential tension from groove to groove, maintaining the same bearing pressure, for ultimate control of conductors, both conventional and OPGW fiber optic. Each bullwheel is controlled by a fully adjustable, articulated, three axis caliper braking system with a ventilated bronze disc. Options include manual retriever, hydraulic retriever, hydraulic spider rewind, spider level wind, and hydraulic power pack to make it independent of any other power source. Conductor reels are easily changed by disengaging the brake from the reel bar.

This manual is of no value if the operator does not read and understand the instructions and precautions (before starting and trying to operate the machine). The operator must be aware of the machine's capacities and limitations. It is the operator's responsibility to watch for situations and conditions which could affect the normal performance of the machine and safety in the work area.

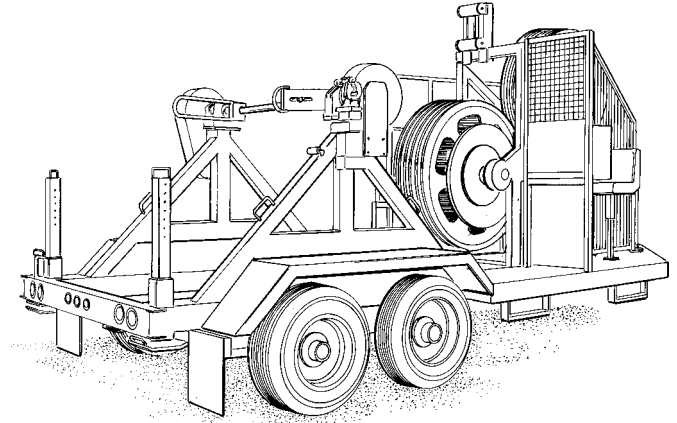

Publication of this manual and the safety precautions in it does not in any way represent an all inclusive list. It is the operator's responsibility to make sure the machine is operated in accordance with all state and local safety requirements and codes, including all applicable OSHA (Occupational Safety and Health Act) and ANSI (American National Standards Institute) regulations.

Should a problem or unsafe condition arise, shut the machine down using the normal shut-down procedure. In the event of an emergency, use the emergency stop procedure. Turn ignition key off, then apply emergency/parking brake. Notify the proper authority or follow your employer's prescribed procedure for an emergency situation.

Sherman & Reilly strongly recommends that only persons literate and understanding the English language be considered as operators or service personnel for this machine.

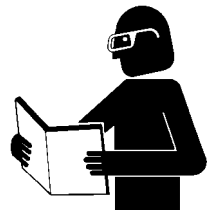

Section 1 • INTRODUCTION

BWT-1545 GENERAL SPECIFICATIONS*

TENSIONER

Maximum Tension Capacity 5,000 lbs.
Maximum Line Speed Four (4) MPH
Bullwheel Diameter 54 inches
Bottom of Grooves 52.5" Diameter
Number of Grooves Five (5)
Groove Radius 1" Standard
Groove Lining Cast Polyurethane
Brake Caliper/Disc 20" Diameter
Brake Control Three Axis Caliper, Manual
Hydraulic (Optional)
Fairlead Roller Adjustable

REEL CARRIER

Maximum Reel Diameter 72"
Maximum Reel Width 54"
Maximum Reel Weight 10,000 lbs.
Reel Shaft 2.625"
Brake Caliper/Disc 16" Diameter
Ventilated Bronze
Brake Control Manual/Optional Hydraulic
Rewind Optional Hydraulic
NOTE: Larger Reel Carrier also available

TRAILER

Overall Length Approx. 23 ft.
Overall Width Approx. 8 ft.
Overall Height Approx. 10 ft. 6 in.
Maximum Gross Vehicle Weight . . . 24,500 lbs.
Axle Capacity (2) 12,000 lbs.
Suspension Leaf Spring
Tire Size 245-70R-17.5L Ply Tubeless
Brake Electric (Standard);
Air (Optional)
Front JackDrop Leg and Screw Type (1);
Hydraulic (Optional)
Rear Jacks Two (2) Drop Leg and Pin Type
Lights 12 Volt
Towing 3" Adjustable Pintle Eye
Safety Chains and Hook Two (2)

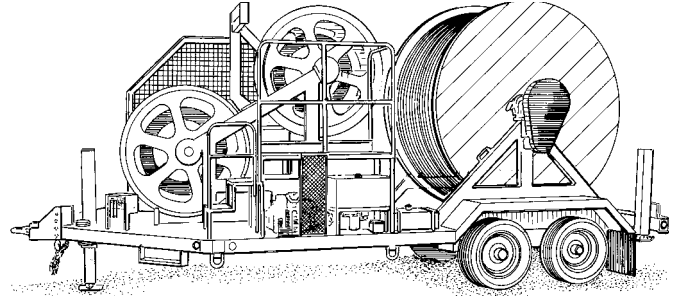

HYDRAULIC SPIDER REWIND (OPTION)

Maximum Torque 10,500 in. lbs.
Maximum Pulling Capacity 700 lbs. on
30" Diameter Reel
Maximum Line Speed Five (5) MPH
Failsafe Brake Spring Applied, Hydraulic
Released, Automatic
Hydraulic Motor Low Speed, High Torque
Spider Levelwind 12-Volt Electric Actuated

HYDRAULIC RETRIEVER (OPTION)

Maximum Torque 28,500 in. lbs.
Maximum Pulling Capacity 1,850 lbs. on
30" Diameter Reel
Maximum Line Speed Two (2) MPH
Hydraulic Motor Low Speed, High Torque

POWER PACK (OPTION)

Engine 18 HP (Gasoline)
Electric Start
Hydraulic Fluid Dexron Quality
Transmission Fluid
Hydraulic System Filtration 10 Micron
Maximum Hydraulic Pressure 2750 PSI
Maximum Hydraulic Flow 10 GPM

* Dimensions, weights, capacities are approximate. Manufacturer's specifications subject to change without notice.

WARNING TERMS

Signal words in this manual call the operator's attention to safety concerns.

DANGER

The word **DANGER** indicates the information relates to a specific immediate hazard which, if disregarded, will result in severe personal injury or death.

WARNING

The word **WARNING** indicates the information relates to a specific immediate hazard or unsafe practice which, if disregarded, could result in personal injury or death.

CAUTION

The word **CAUTION** indicates the information pertains to a potential hazard or unsafe practice which, if disregarded, may result in minor personal injury or equipment damage.

NOTE

The word **NOTE** indicates the information is important to the correct operation or maintenance of the machine.

OPERATOR SAFETY PRECAUTIONS

DANGER

Do not place any part of the body into a potential pinch point. The machine must be turned off and locked out in accordance with OSHA regulations before attempting to correct a problem, working on the machine, or performing regularly scheduled service.

Do not attempt to operate **Sherman & Reilly** equipment without proper instruction, including reading and understanding the manual.



Obey and enforce all warnings including OSHA requirements and ANSI standards.

Never allow anyone to ride on the unit while it is being towed.

Always wear proper safety equipment as required by employer.

Never bypass safety switches or operate equipment with faulty safety devices.

Be sure all guards and access covers are secure in place when the machine is being operated.

Be aware of people in the work area who may be at risk during operation.

Know all emergency shut-down procedures.

Do not obstruct controls or fire extinguisher.

Make sure fire extinguisher is fully charged.

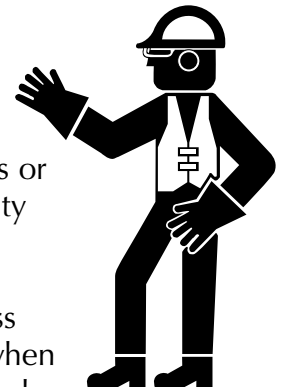

Section 2 • SAFETY

Never operate equipment while under the influence of any substance which could impair operator ability or judgement. This presents a safety hazard in the work place.

Always use employer approved grounding procedures when operating the machine.

Do not operate equipment if work ability is impaired by fatigue, illness, or other causes.

Never use hands to check for hydraulic system leaks. Hydraulic fluid escaping under pressure can cause personal injury.

Keep all body parts, head, and limbs away from all moving parts.

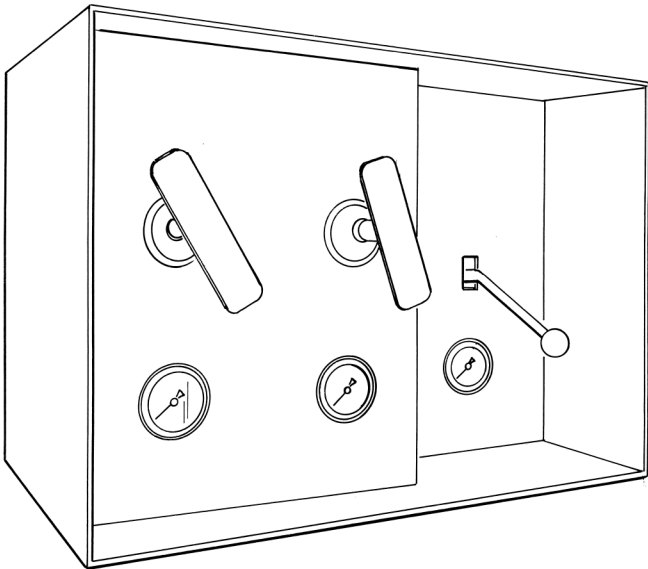

Know location and function of all controls, gauges, instruments, and protective devices.

Never use controls or hoses for hand holds.

Do not climb on machine – use the operation platform.

Do not exceed unit specifications and limitations for weight.

Know where to get help in the event of an emergency or injury.



Maximum towing speed is 60 miles per hour. Towing speed may be slower in certain conditions.

Avoid contact with pumps, hoses, engine components, and exhaust system. (Optional Power Pack Only)

Do not refuel unit while the engine is running or hot. (Optional Power Pack Only)

Do not jump start with cable ground connection directly on the battery. (Optional Power Pack Only)

Do not make physical contact with rope, cable, or conductor as it enters or leaves machine or reel.

To prevent the possibility of electrocution, do not enter or leave the unit while it is operating or allow anyone to touch or lean on the machine when in use.



EMPLOYER SAFETY REQUIREMENTS

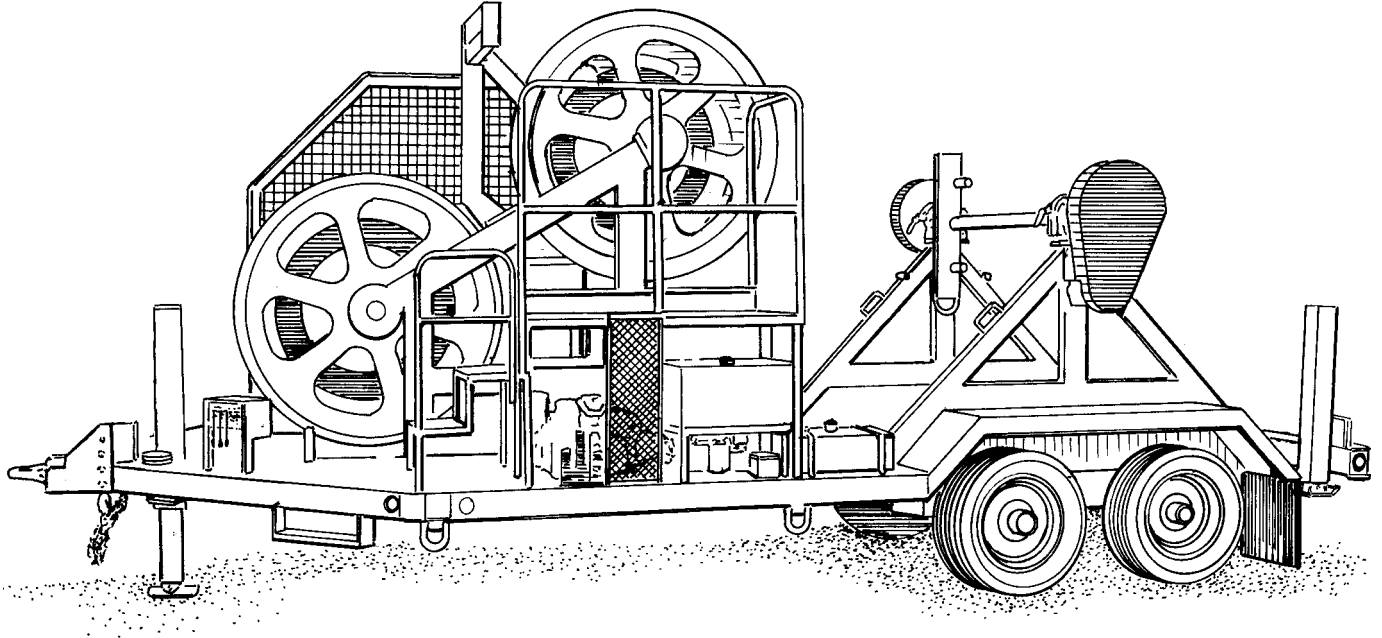

This guideline is intended to assist owners/employers to ensure equipment is serviced and operated in a safe manner. Each job site may have additional situations and conditions which need consideration.

Monitor the operators to be sure they observe and practice safety procedures and operate the support equipment as outlined in this manual.

Establish a regular inspection program which includes malfunction reports, inspection, and service records. This inspection should cover the machine condition, adjustment, and ensure all safeguards are in place and functional.

Make sure that any malfunction or breakdown that will affect the safe operation of the equipment is properly corrected or repaired before returning machine to service.

The employer shall provide training and instruction in safe methods of work before assigning workers to operate, service, or repair the equipment. A record of training dates, employee names, and level of training should be maintained. Only persons literate and understanding the English language should be considered to operate this machine.

Employer shall utilize a lock-out/tag-out procedure which complies with part 1910.147 of Title 29 of the Code of Federal Regulations (OSHA). The procedure will include control of all keys.

The employer will specifically inspect all safety equipment and protective devices on the equipment to ensure they are not bypassed or disabled. Operation of the equipment will not be permitted unless all safety devices are functional and in place. The employer shall meet the appropriate protection requirements for the workers.

Section 2 • SAFETY

DESCRIPTION OF OPERATING CONTROLS

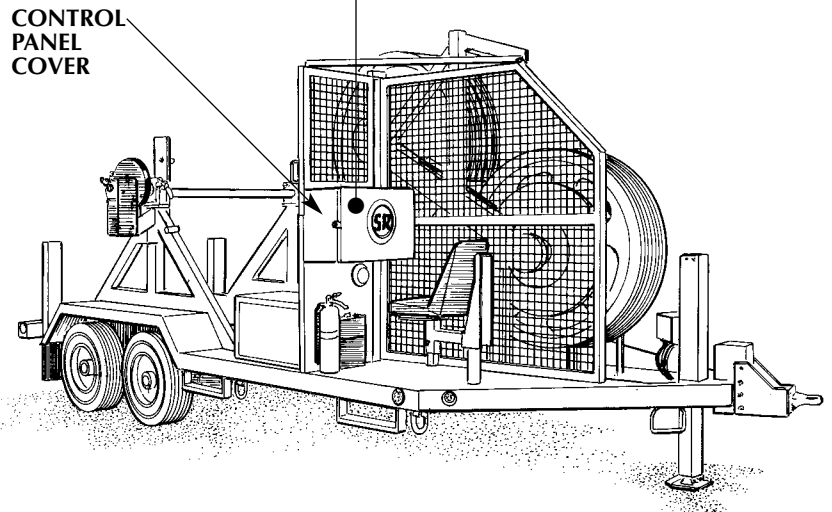
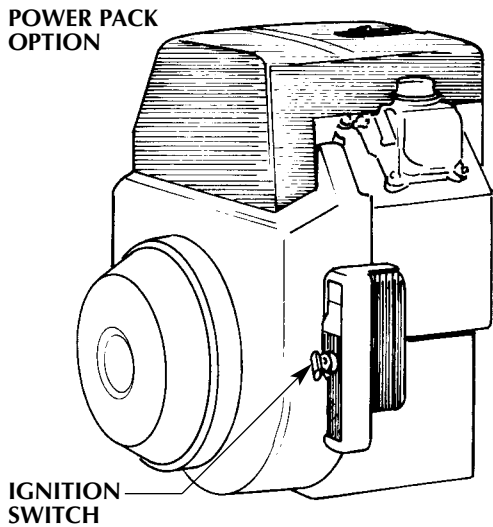
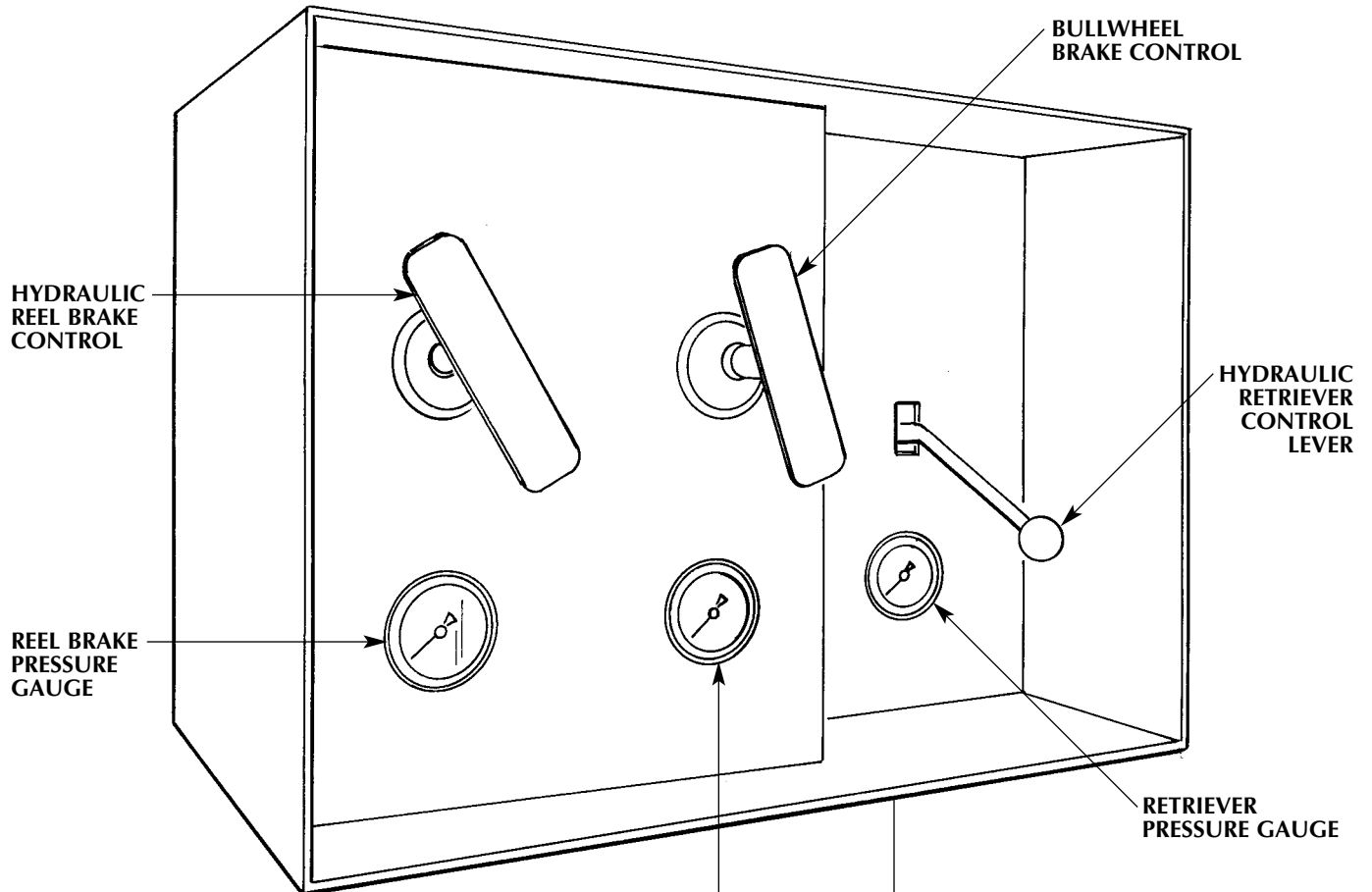

Section 3 • OPERATION

DESCRIPTION OF OPERATING CONTROLS

BULLWHEEL BRAKE CONTROL

This handle is used to increase or decrease the pressure applied to the bullwheel brakes.

BULLWHEEL BRAKE PRESSURE GAUGE

This gauge indicates the amount of pressure applied to the bullwheel brakes, measured in pounds per square inch (PSI).

REEL BRAKE CONTROL

This handle is used to increase or decrease the pressure applied to the payout brake on the reel.

REEL BRAKE PRESSURE GAUGE

This gauge indicates the amount of pressure applied to the payout brake on the reel, measured in pounds per square inch (PSI).

HYDRAULIC RETRIEVER CONTROL LEVER (OPTIONAL)

This three-position control lever controls the speed and direction of the hydraulic retriever. The lever returns to the neutral position when released.

RETRIEVER PRESSURE GAUGE

This gauge indicates the amount of pressure applied to the retriever, measured in pounds per square inch (PSI).

PAYOUT/PULL-IN CONTROL PILOT LINE SYSTEM (Spider Rewind Option)

This three-position lever is used to operate the "rewind unit". It controls the direction of travel and speed. The lever is proportional; the further the lever is moved, the faster the reel rotates. The lever returns to the neutral position when released.

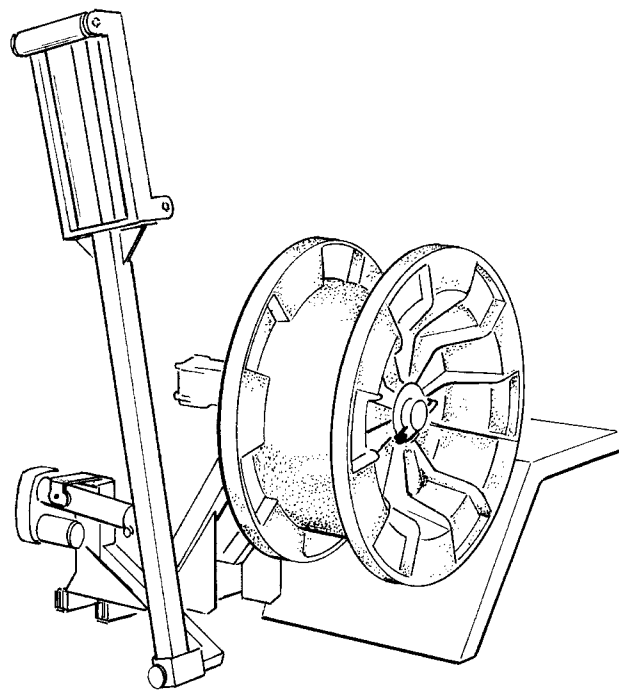

LEVELWIND CONTROL (Spider Levelwind Option)

The levelwind is used in conjunction with the rewind unit when pulling-in pilot line. This switch is used to oscillate the levelwind arm left to right so the pilot line is evenly applied to the storage reel. The lever returns to the neutral position when released.

IGNITION SWITCH (Power Pack Option)

Key-operated three-position switch. Turn key to "start" engine. When released, the switch will return to the on "run" position. Turn the key to "off" to turn the engine off.

TERMS YOU NEED TO KNOW

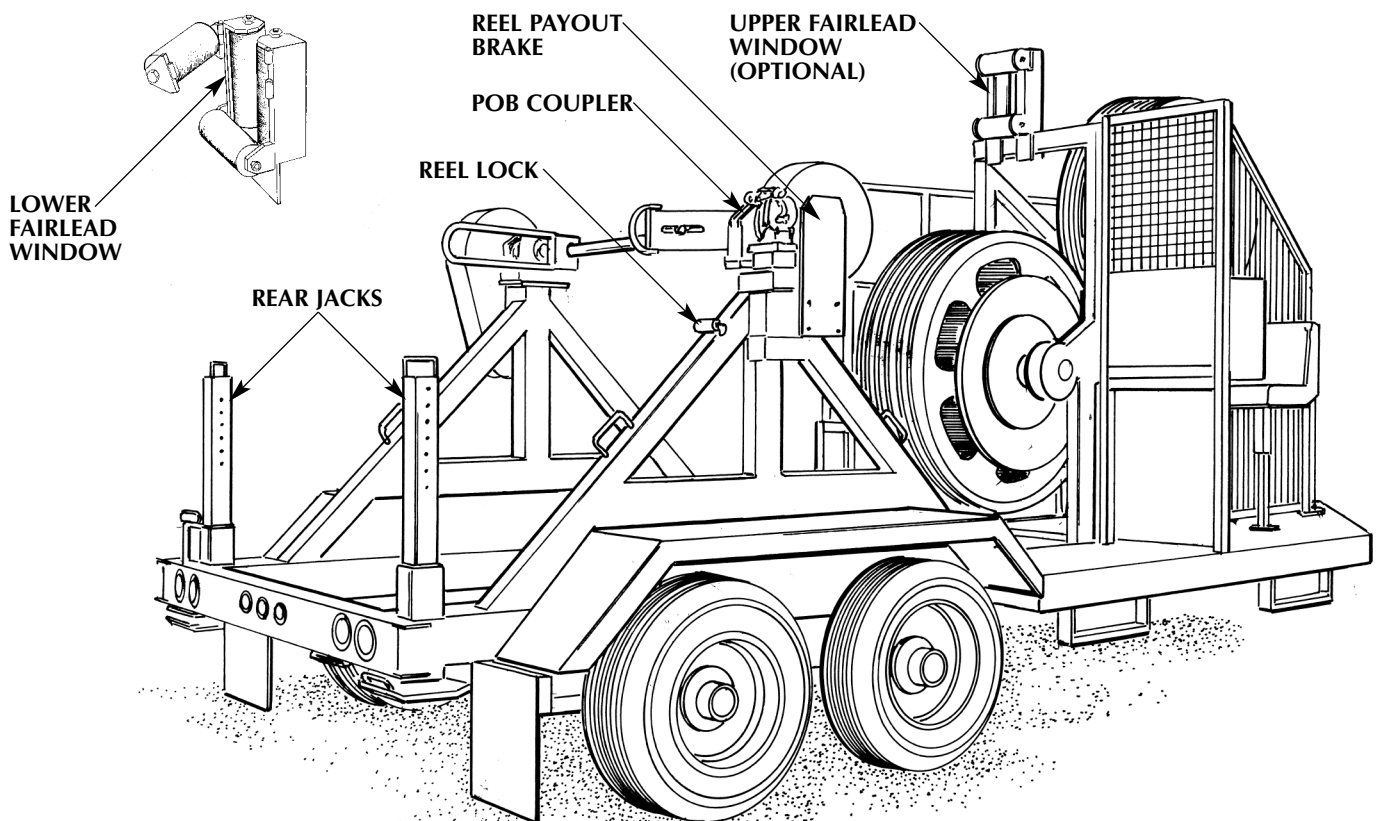
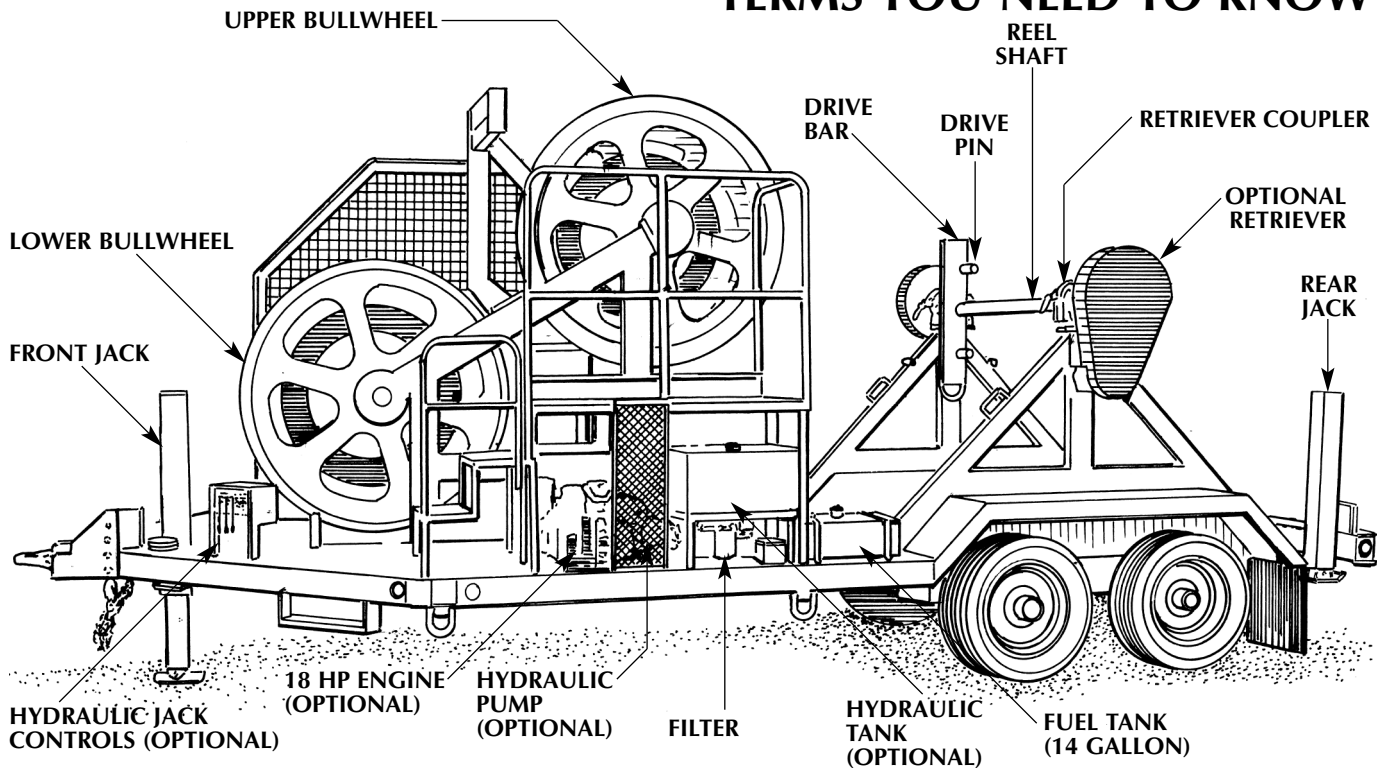

Section 3 • OPERATION

TERMS YOU NEED TO KNOW

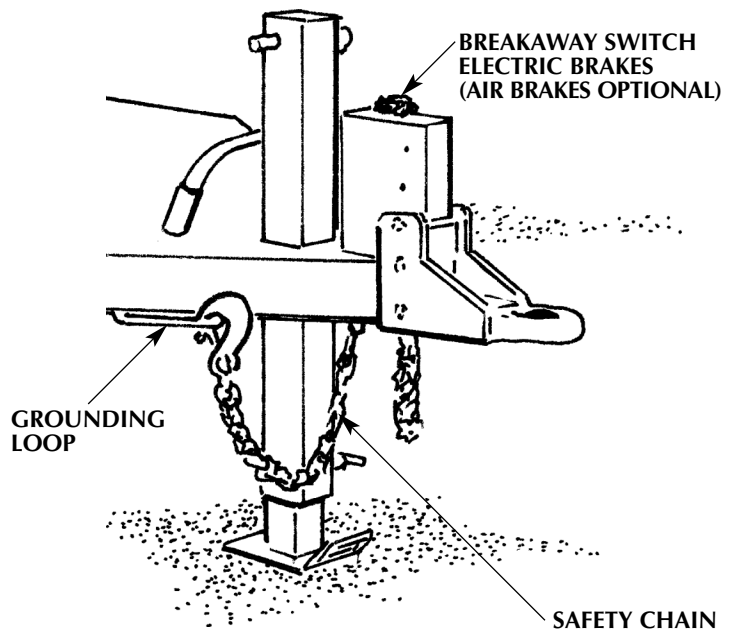
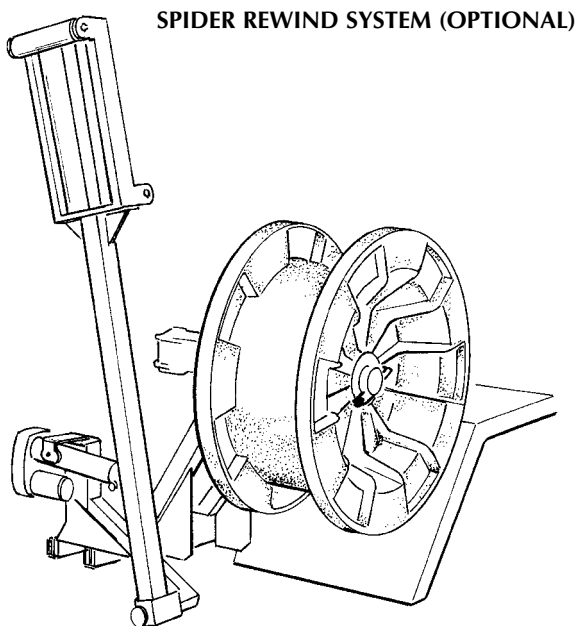
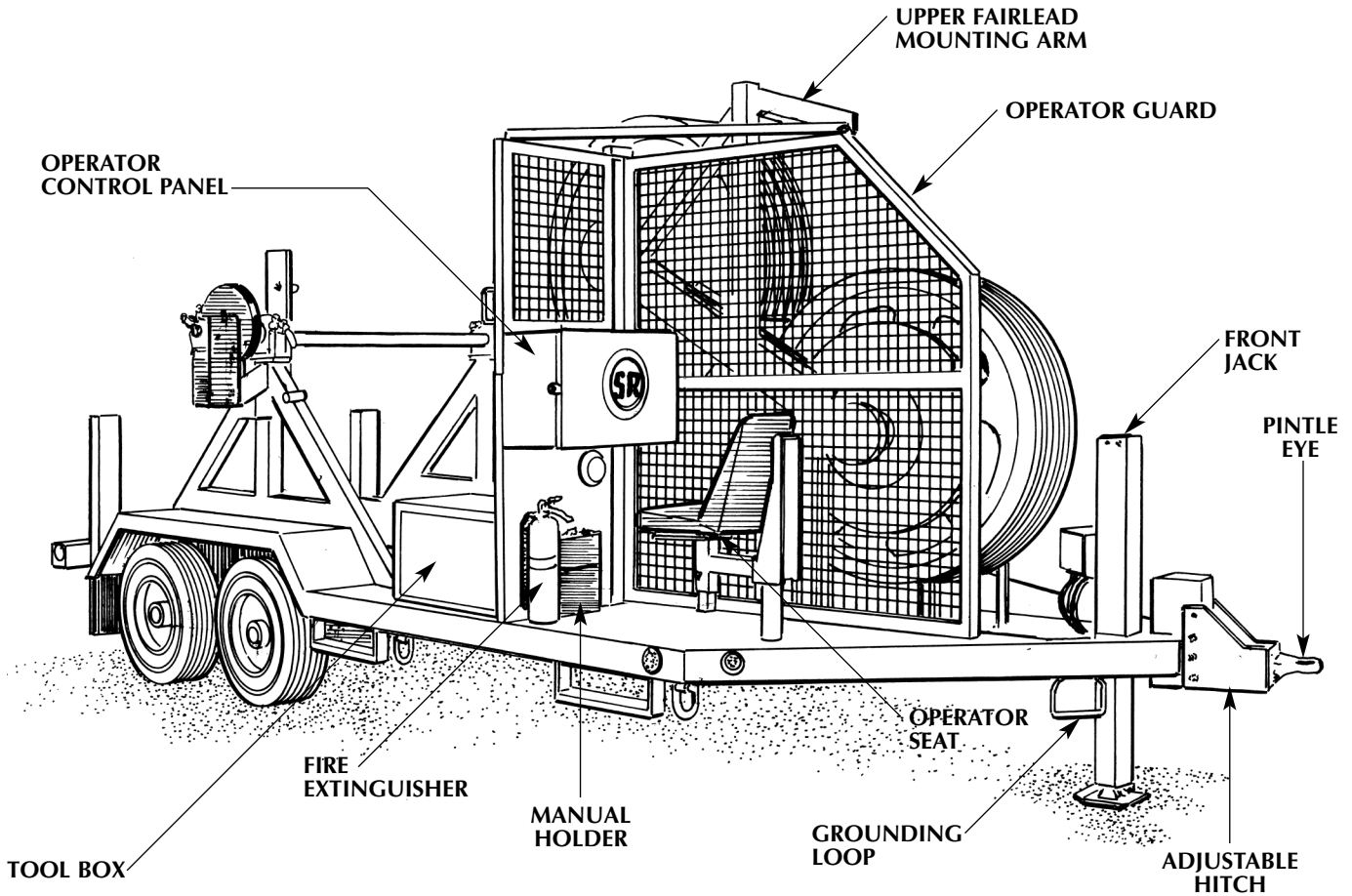

TOWING

Connecting the tensioner to the tow vehicle:

1. Make certain the tow vehicle has the capacity and rating to tow safely.
2. Inspect pintle eye and safety chains for excessive wear, corrosion, cracked welds or structural damage.
3. Inspect tow vehicle hitch and ensure hitch has no worn or damaged parts.



Do not attempt to tow if there is any question about the service condition of the safety chains or hitch.

4. Make sure the unit is ready for towing.
 - a. Tires are in good condition and properly inflated.
 - b. Correct fluid level in both wheel hubs.

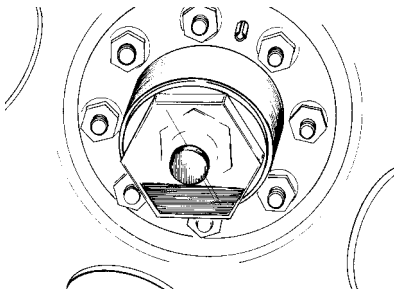

- c. Make sure the rear leveling jacks are in the full up position, and secured.
 - d. Make sure there are no tools, objects, or debris on the unit which could fall off the machine during transport.
5. Chock or block the wheels on both sides of the machine.
6. Use the front jack to raise or lower the pintle eye to the correct height for the tow vehicle hitch.

8. Open the tow vehicle hitch and back into position under the pintle eye. Set the parking brake on the tow vehicle.
9. Close and secure the tow vehicle hitch.



The hitch coupler is a pinch point. Keep hands and fingers clear.

10. Attach the break-away switch cable to the tow vehicle.
11. Properly connect the safety chains. The safety chains should be crossed and short enough to prevent the tongue from digging into the ground, should the unit unintentionally become disconnected. The chains should be no longer than necessary to allow slack for turning – crossing the chains provides directional control.

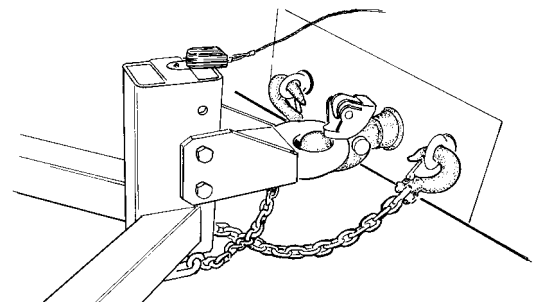

12. Completely retract front jack.
13. Connect the electrical plug to the tow vehicle and check clearance lights, brake lights, turn signals and brakes.



Do not tow the unit unless all lights and brakes are working correctly.

14. Remove the wheel chocks or blocks.

Section 3 • OPERATION

SET-UP TO TENSION

1. Position the tensioner in a suitable location. When installing overhead the tensioner should be approximately three times the distance of the first structure/pole height.
2. The unit should be set up as level as possible, centered on the lead block and parallel to the line being pulled. Chock or block the trailer tires on both sides and disconnect from the tow vehicle. Level the unit using all three jacks.

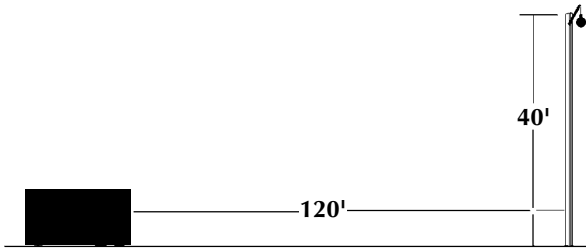

Example: If the first structure/pole is 40 feet high, it is recommended the tensioner be approximately 120 feet from the base whenever possible.

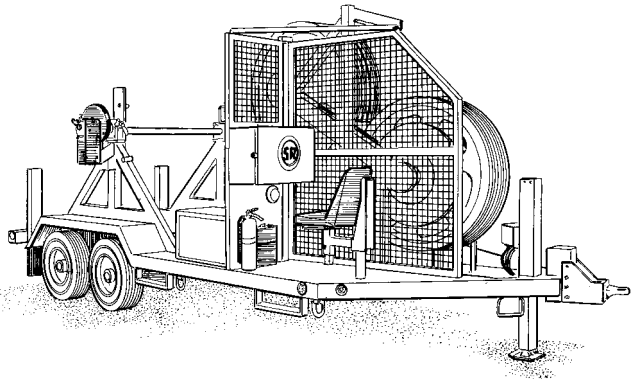

NOTE

Most of the weight should be off of the tires and axles.

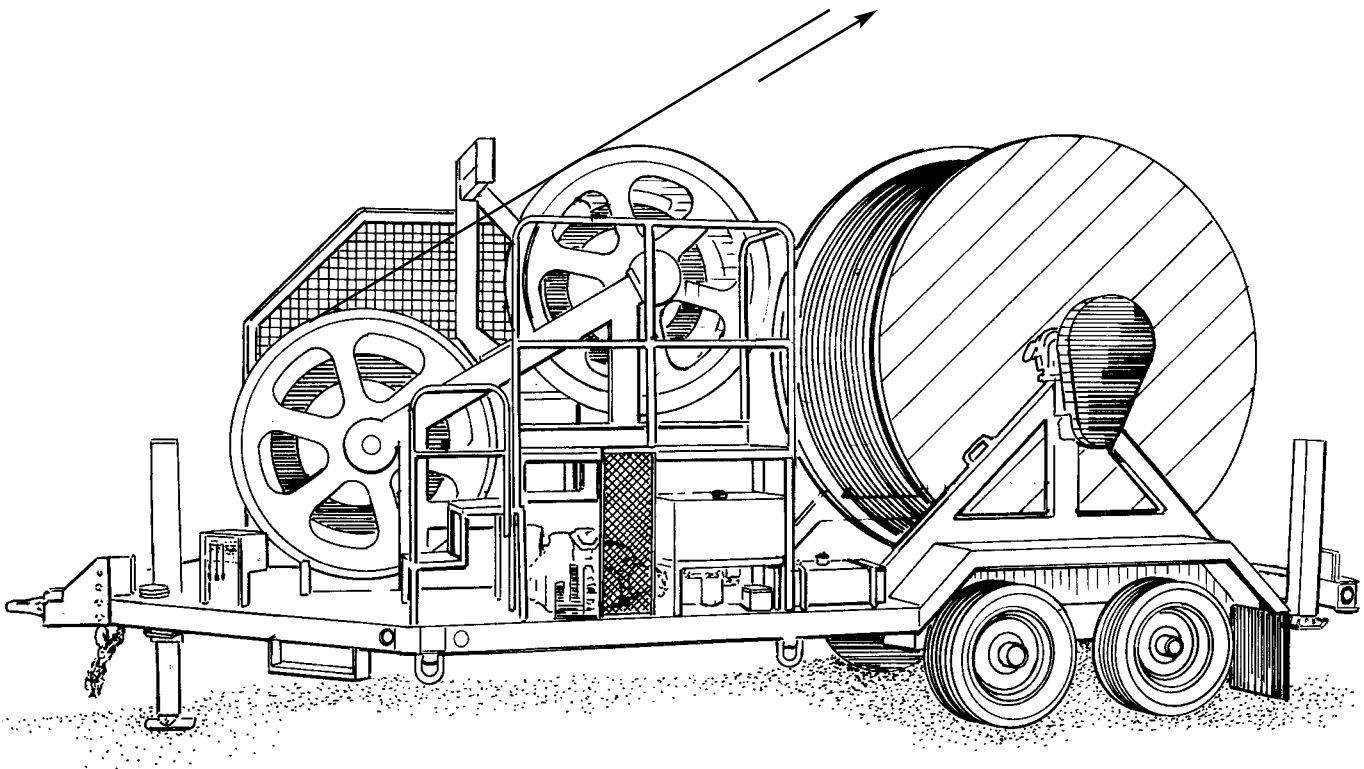

REEL INSTALLATION/REMOVAL

The procedure for installing or removing a reel is the same for all types of reels.

▲ CAUTION

Make sure there is adequate overhead clearance with no obstructions before attempting to remove or install a reel.

1. Disengage the payout brake coupler from the reel shaft.

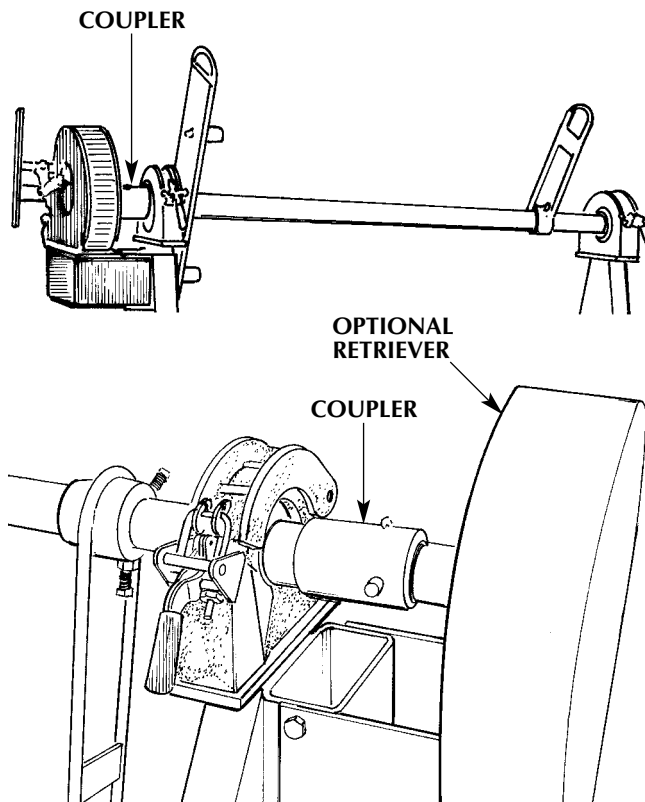

NOTE

On units with optional hydraulic retriever, the retriever must be disengaged.

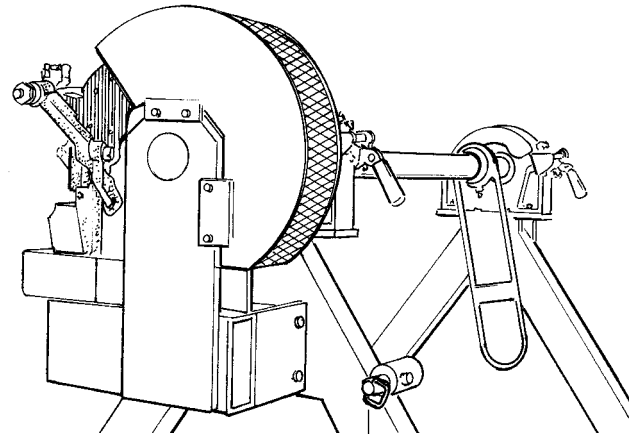

NOTE

Make sure the reel locking pin is unlocked.

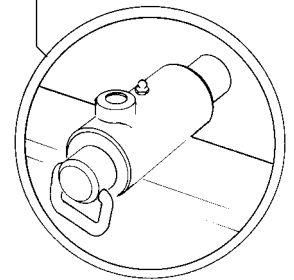

2. Remove the locking pins and unlatch the pillow block housing on both sides. Rotate the top of the housing to the full open position and make sure the latch is folded back out of the way.

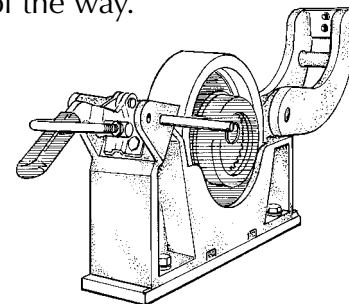

3. Use a spreader bar on the chains to the lifting device to lift the reel and drive bar assembly up out of the pillow block housing.

▲ CAUTION

Lift straight up, keeping the bar level with the machine, to prevent the bearings from binding in the pillow block housings and possibly causing damage to the machine.

Section 3 • OPERATION

4. Remove the bearing from the end of the drive bar, loosen the set screws and remove the lifting eye/tapered cone.

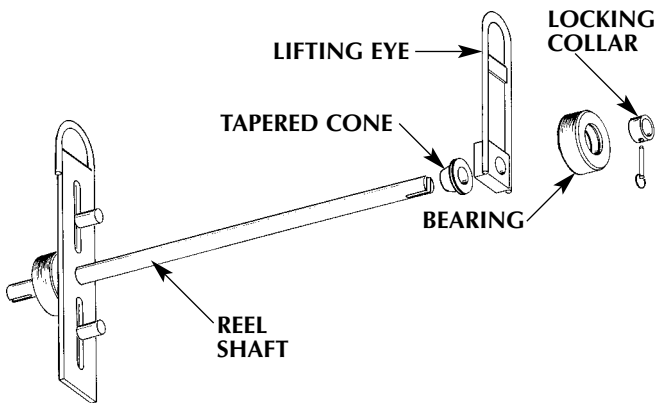

NOTE

The conductor reel should be placed so that the conductor will feed off the bottom of the reel, through the fairlead window, to the front of the machine.

5. Slide the drive bar into the reel to be installed. Adjust the drive pins if necessary.
6. Slide the reel lifting eye/tapered cone onto the drive bar.

NOTE

Two (2) sizes of tapered cone lifting collars are provided. Be sure to use the proper size based on the diameter of the arbor hole.

NOTE

The tapered cone is turned in and slid into the arbor hole on wooden reels when necessary to stabilize the reel.

7. Align the reel lifting eye with the lifting eye on the drive bar and tighten the set screws.
8. Slide the bearing into place on the drive bar.
9. Attach the lifting device chains with a spreader bar to the reel and drive bar lifting eyes.
10. Position the reel over the pillow block housings and lower the reel into place.

NOTE

Lower the reel straight and level with the machine to keep the bearings from binding in the pillow block housings as the reel is lowered into position.

11. Remove the lifting device, close, latch and secure the pillow block housings with the locking pins.
12. Rotate the reel by hand to make sure it moves freely and turns correctly.

REEVING THE BULLWHEELS

1. All brakes must be released.
2. Start by reeving a synthetic rope around the bullwheels. Attach the synthetic rope to the conductor and pull the conductor onto the bullwheels.

NOTE

The tensioner is designed for the conductor to feed off the bottom of the reel, through the lower fairlead window, to the front of the machine.

3. The top roller on the fairlead windows will open to allow you to insert or remove the conductor.

FAIRLEAD

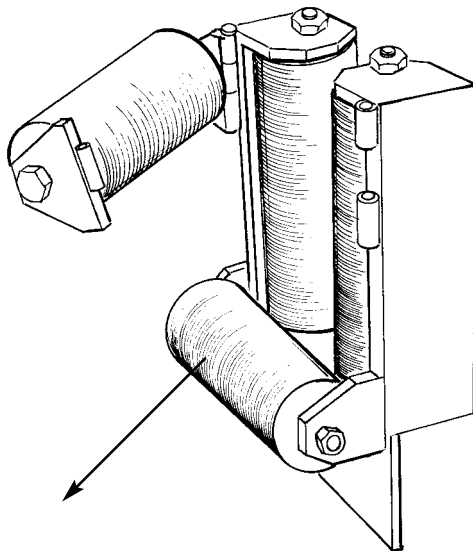

4. The conductor will enter the far right groove of the lower bullwheel, reeve around the bullwheels and exit the far left groove of the upper bullwheel, going out the back of the unit and up to the first structure.

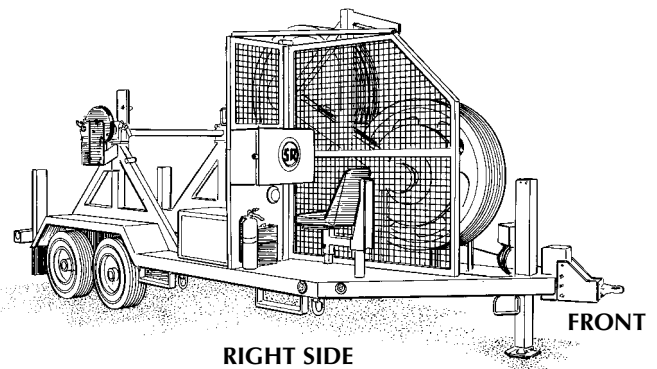
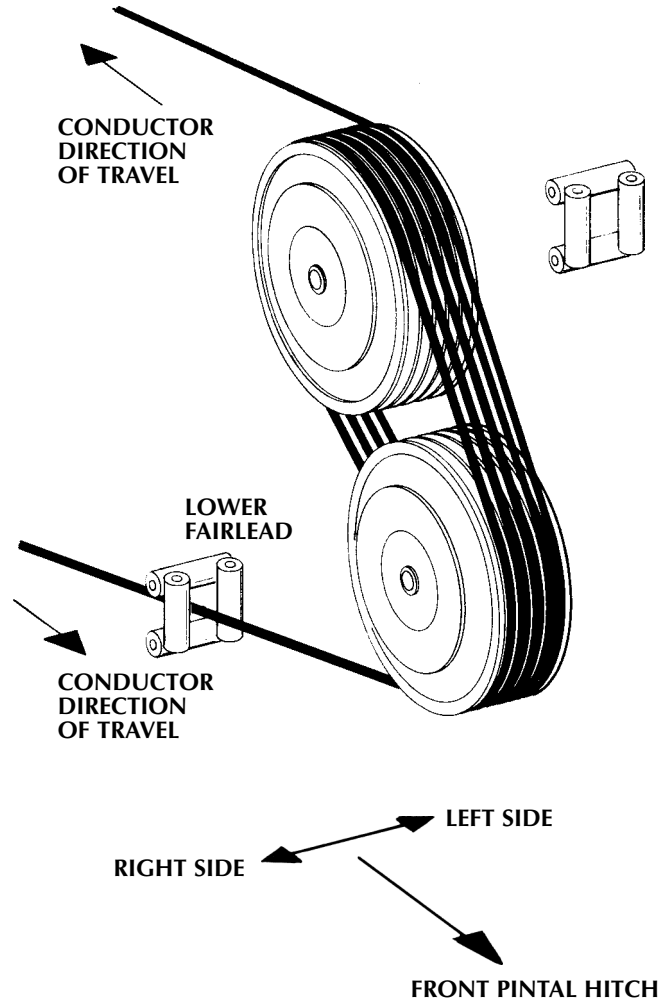

Section 3 • OPERATION

5. The unit is also designed to work using reel stands or other reel trailers. When using one of these options, the conductor enters the tensioner from the front, through the optional upper fairlead window. It will enter the far right groove of the upper bullwheel, reeve around the bullwheels and exit the far left groove on the upper bullwheel, going out the back of the unit and up to the first structure.

FAIRLEAD

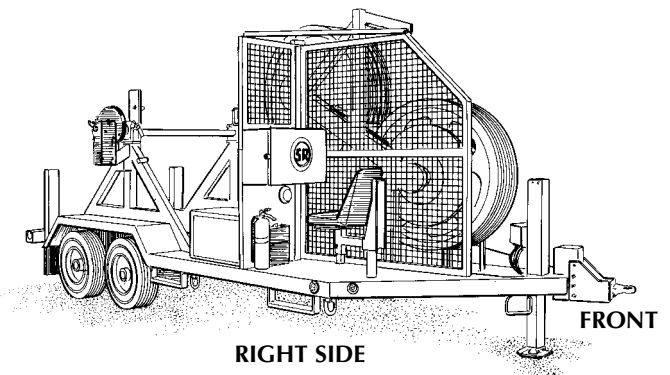
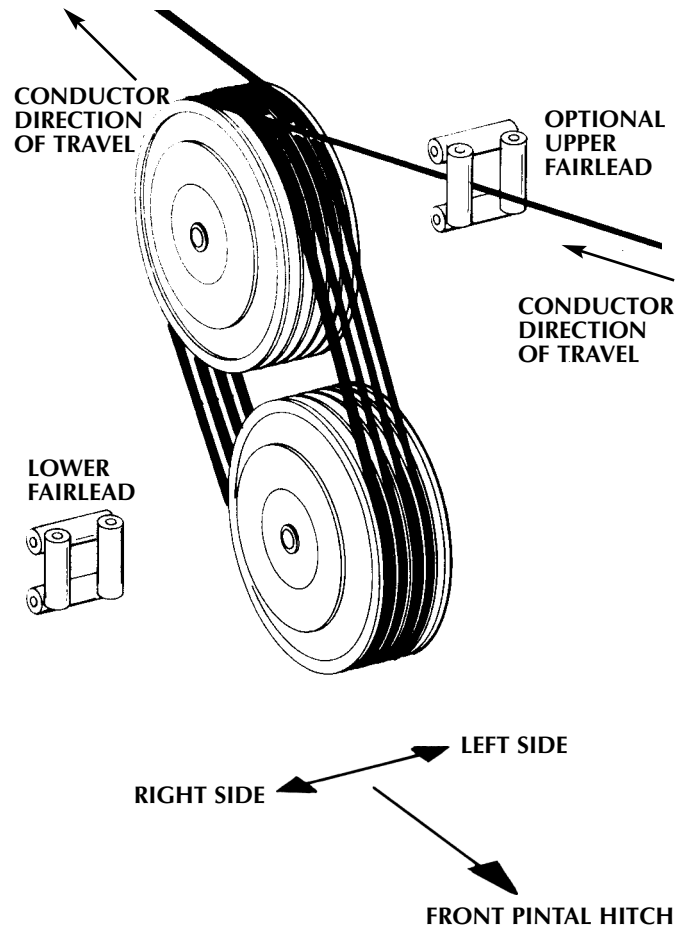
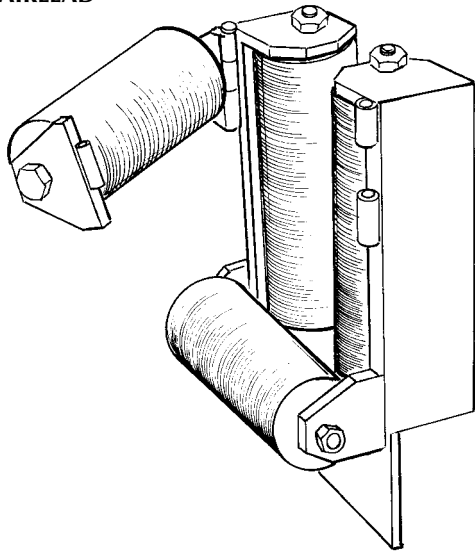

TENSIONING

If the situation permits, it is better to set the brakes moderately and adjust upward to the desired stringing tension. For smoother operation, it is recommended that the over-spin brake on the conductor reel be set as lightly as the job will permit. The tensioning force should be generated and regulated by the bullwheel brakes. The bullwheel brakes should be adjusted evenly. If one brake appears to be heating more than the other, then the braking force on it should be decreased and the braking force on the other should be increased.

▲WARNING

Keep hands, arms, and other parts of the body and all clothing away from all moving parts or severe injury is possible.

On units with manual brake controls, rotate the handle clockwise to increase tension and counter-clockwise to decrease tension.

The machine is equipped with reel locking pins. They should be engaged when transporting the reel or when leaving the conductor under tension for long periods of time.

REEL LOCKING PIN

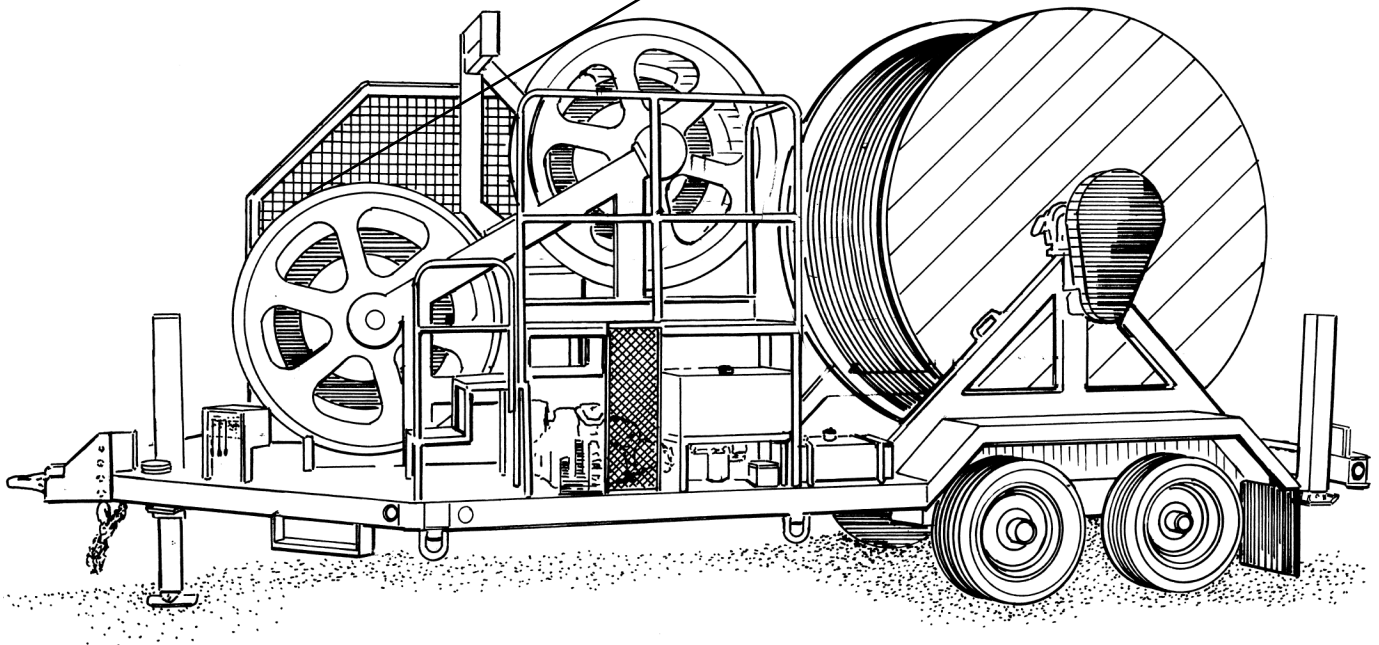
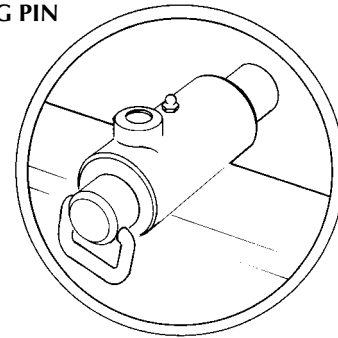

Section 3 • OPERATION

HYDRAULIC RETRIEVER (OPTIONAL)

The retriever device is intended for rewinding only short sections of conductor onto the reel. The unit is engaged by connecting the drive shaft to the reel shaft with a sliding coupling.

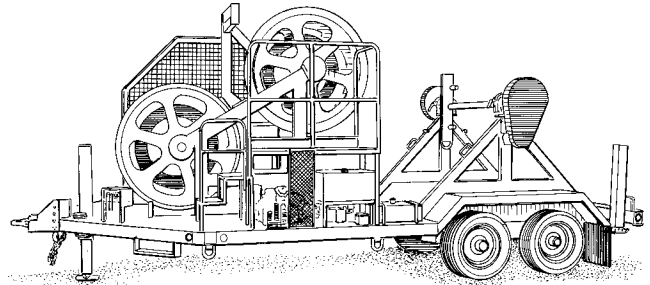
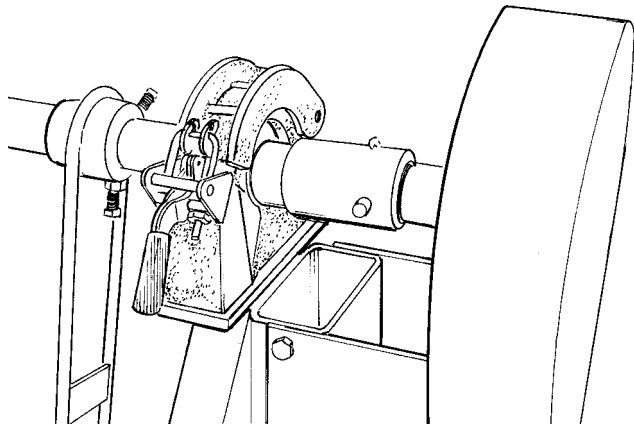

The drive motor is operated with a three-position control lever which returns to neutral when released. The distance the lever is moved controls the amount of pressure / speed generated by the retriever.

▲ CAUTION

This unit was designed to retrieve loose cable or rope and should not be used as a "puller".

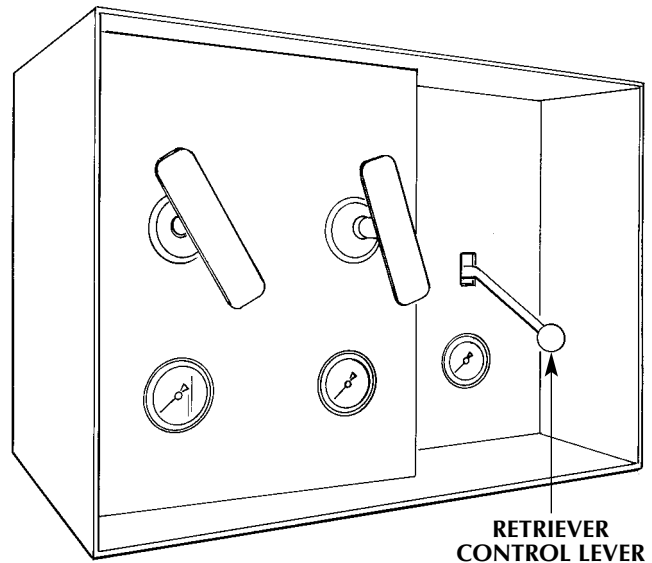

▲ CAUTION

Be sure the retriever is disengaged before tensioning.

INSTALLING PULLING GRIP

1. Select the correct size grip. (Refer to manufacturer's chart or specifications.)
2. Use a feed tube or contain the end of the rope or conductor. Slide the grip into place.
3. Lock the mesh on the tail end of the grip to the rope or conductor, using two punch-lok bands, positioned 1" to 2" from tail of grip.

NOTE

The conductor or rope should be installed up to the elbows of the aluminum shoulders to assure full and complete gripping action.

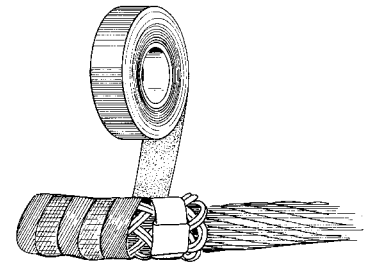
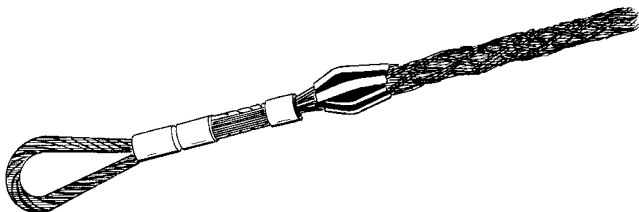

4. It is a good practice to apply tape over the banded grip tail only, to assure smooth passage through the sheaves. Do not tape the entire grip.

SPIDER REWIND SYSTEM (OPTIONAL)

The spider rewind system is used to wind up spider line or pilot rope when pulling the bull line through the stringing blocks. The rewind system utilizes a levelwind to ensure smooth even distribution of the pilot line onto the spider reel.

1. Move the spider rewind control to pull the line over the top of the drum. The lever must be held to operate the unit.
2. As the spider line/pilot line goes on the reel, move the levelwind control back and forth gradually to wind the cable on the reel evenly.

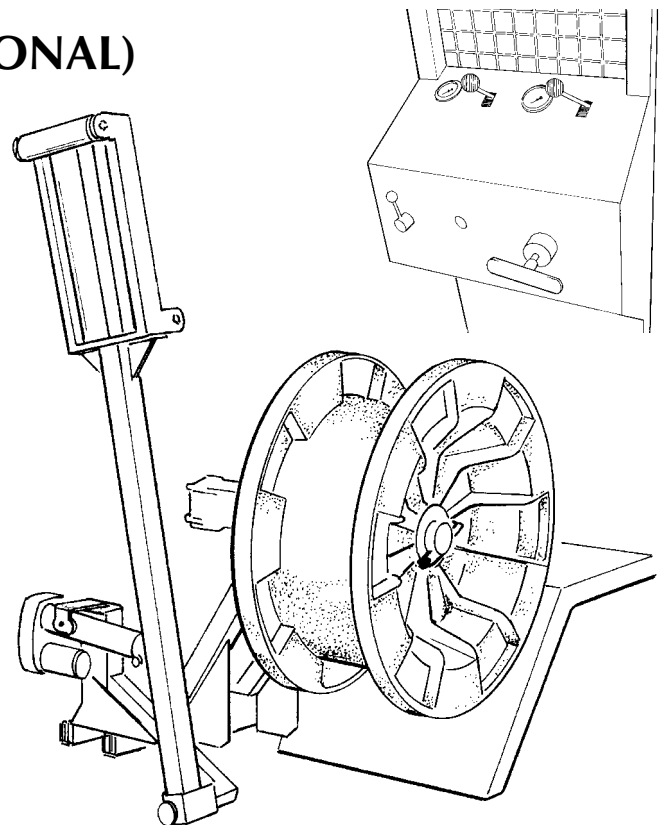

Section 3 • OPERATION

GENERAL SERVICE

Close attention to proper preventive measures and service procedures will ensure and extend trouble-free operation of equipment. Proper lubrication and careful attention to the hydraulic system suction filter are two vital areas. The objective of scheduled service should be to anticipate and prevent operational problems before they require extended shutdown for repairs.

Refer to the engine manufacturer's manual for all service related information, oil and fuel requirements on units with power pack option.

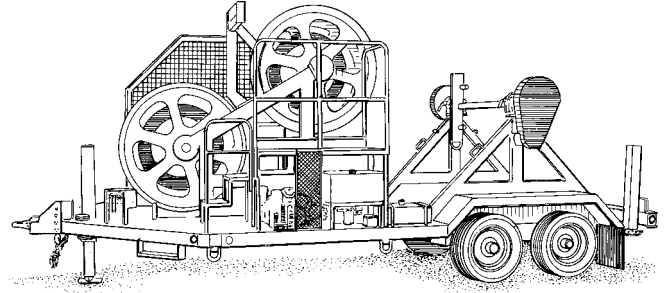

IMPORTANT INFORMATION

WARNING

The service guidelines outlined in this manual are effective methods. These guidelines are not all inclusive. Anyone who performs service or repair on a Sherman & Reilly machine must be completely satisfied that no one's safety will be jeopardized and take responsibility for these actions.

If there are any questions about safety, procedure or precautions, contact **Sherman & Reilly** at **800-251-7780** before attempting to do the work.

Service should be scheduled to allow adequate time so the procedure can be completed correctly. It must be done by skilled, trained service personnel with a good basic knowledge of equipment, procedures, and safety practices.

Accurate records should be kept of all service and repairs.



Section 4 • SERVICE

SAFETY PRECAUTIONS

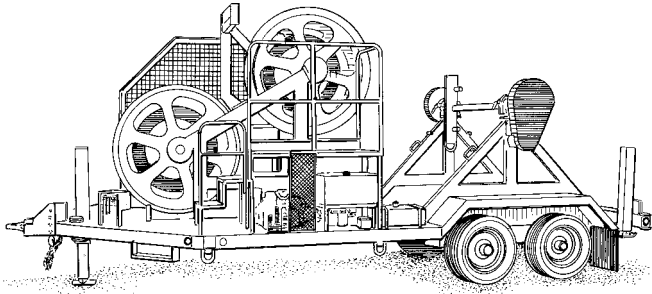

1. Make sure the machine is locked out in accordance with OSHA requirements.
2. Make sure that all precautions are taken to support components before loosening or removing bolts.
3. When working on any hydraulic connection or part:
 - a. Be sure there is no pressure on fluid at the location of the work.
 - b. Make sure nothing will move or drop when loosening a connection.
 - c. Collect all the hydraulic fluid which will drain from the loosened connection.
 - d. Use oil-dry or some absorbent material to soak up any fluid spills to keep working surfaces from becoming slippery.
 - e. Cover all open connections to prevent loss and contamination to the hydraulic system.



4. Take all fire prevention safety measures before using a welder or cutting device, including grinders. Have a fully charged fire extinguisher near the location of the work.



5. Be sure everyone involved in the maintenance, service or repair process understands what is being done and all of the safety precautions which need to be taken during the procedure.
6. Make sure all lifting devices, chains, slings, and hooks are in good condition and have the rated capacity to do the job. Use guide lines when necessary for control during the lifting process.
7. Always wear proper protective clothing and equipment when performing service: gloves, safety glasses, etc.

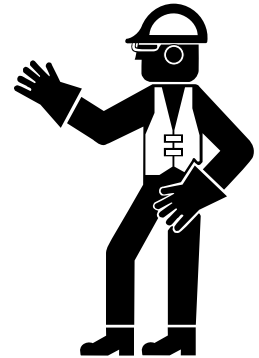

HYDRAULIC SYSTEM (OPTIONAL POWER PACK)

Absolute cleanliness of the hydraulic system is a must! The smallest amount of foreign material in the system can cause extensive damage to the pump, motor or valves. **Sherman & Reilly** has taken every precaution to assure that each component and fitting was thoroughly cleaned and the system purged before this machine was delivered. Therefore, maintenance of the system should be carried out with extreme care.

ADDING HYDRAULIC OIL

Wipe all dirt and grime from around reservoir filler cap before removing.

ENGINE

Refer to engine manufacturer's manual for service requirements.

COMPONENT REPLACEMENT

When replacing hoses, fittings or other components, clean thoroughly and then assemble carefully.

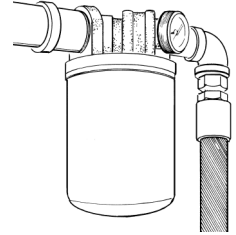

NOTE

The hydraulic fluid and filter should be changed after the first 25 hours of operation.

NOTE

A quality ISO grade hydraulic fluid should be used. Kendall Hyken Golden MV hydraulic fluid is put in at the factory.

Section 4 • SERVICE

SERVICE REQUIREMENTS

CALIPER DISC BRAKES ON REEL CARRIER/BULLWHEEL

The brake linings should be inspected weekly and replaced before the rivet heads damage the brake disc.

AXLE

The wheel bearing reservoirs should be visually inspected before towing the machine and maintained at the level line with SAE-90, SAE 80W-90, SAE 80W-85W-90, or SAE 75W-90 Hypoid gear oil. The wheel bearings should be replaced as necessary.

WHEEL MOUNTING

It is important to maintain proper torque specifications to ensure safe and secure attachment of the wheel to the hub.

NOTE

Start lug nuts by hand to prevent cross threading.

Tighten lug nuts in three stages using a cross star pattern. When using clamp ring and 90° cone nuts, tighten the wheel nuts to a final torque of 200 ft. lbs.

The proper torque must be maintained by checking every 50 miles for the first 200 miles, then per periodic maintenance and after every charge in wheel mounting.

TRAILER BRAKES

The brakes are self-adjusting. When the leading shoe leaves the anchor pin during a reverse brake application, the adjuster cable pulls the adjuster pawl upward to engage the next tooth of the adjuster star wheel if adjustment is necessary due to normal wear. To release the shoes, the adjuster pawl must be pulled away before the star wheel can be turned backward to decrease brake adjustment. To obtain access to the adjuster, remove the bottom half of the dust cover. When reinstalling the dust cover, tighten to five ft. lbs.

NOTE

Over torquing may damage the cover.

Upon reinstallation, the shoes should be adjusted to the point of lightly dragging the drum and with approximately .010" of clearance on the shoe with the most shoe to drum clearance measured at the 3 or 9 o'clock position.

The brakes should be checked for adjustment every 3000 miles or six months and the linings inspected for wear and contamination every 5000 miles and replaced as necessary. Actual service may indicate more frequent adjustments.

BULLWHEEL ASSEMBLY

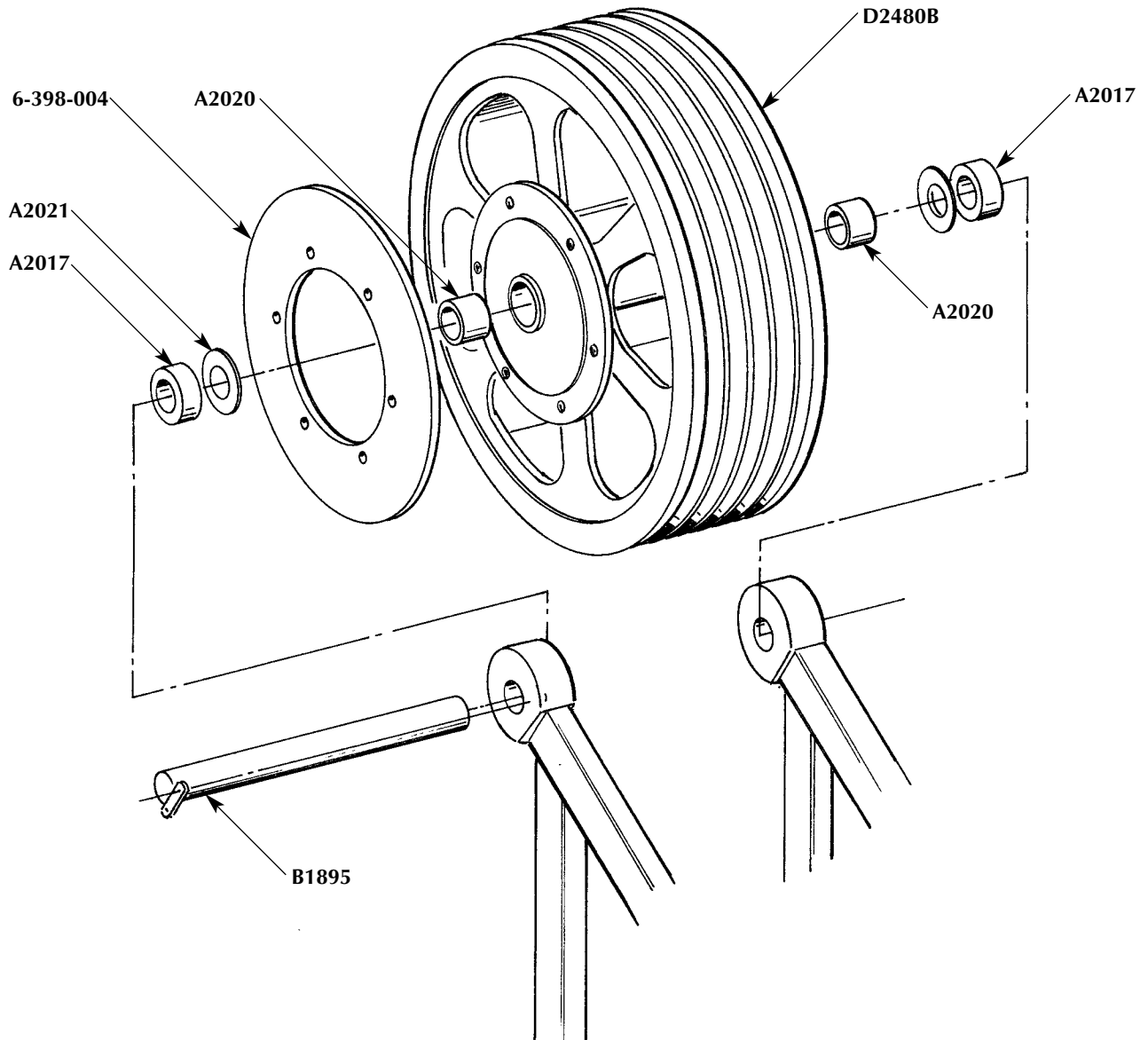

Part #	Description	Qty.
A2017	Bullwheel Shaft Spacer	
A2017-5	Bullwheel Shaft Spacer (4/3/2016)	1
A2017-6	Bullwheel Shaft Spacer (2/13/2016)	2
A0217-7	Bullwheel Shaft Spacer (1/3/2008)	1
A2020	Oil Impregnated Bronze Bushing	4
A2021	Oil Impregnated Bronze Washer	4
B1895	Bullwheel Axle Shaft	2
D2480-B	Five Groove Bullwheel	2
6-398-004	36" Brake Disc	2

Section 5 • PARTS

36" BRAKE CALIPER

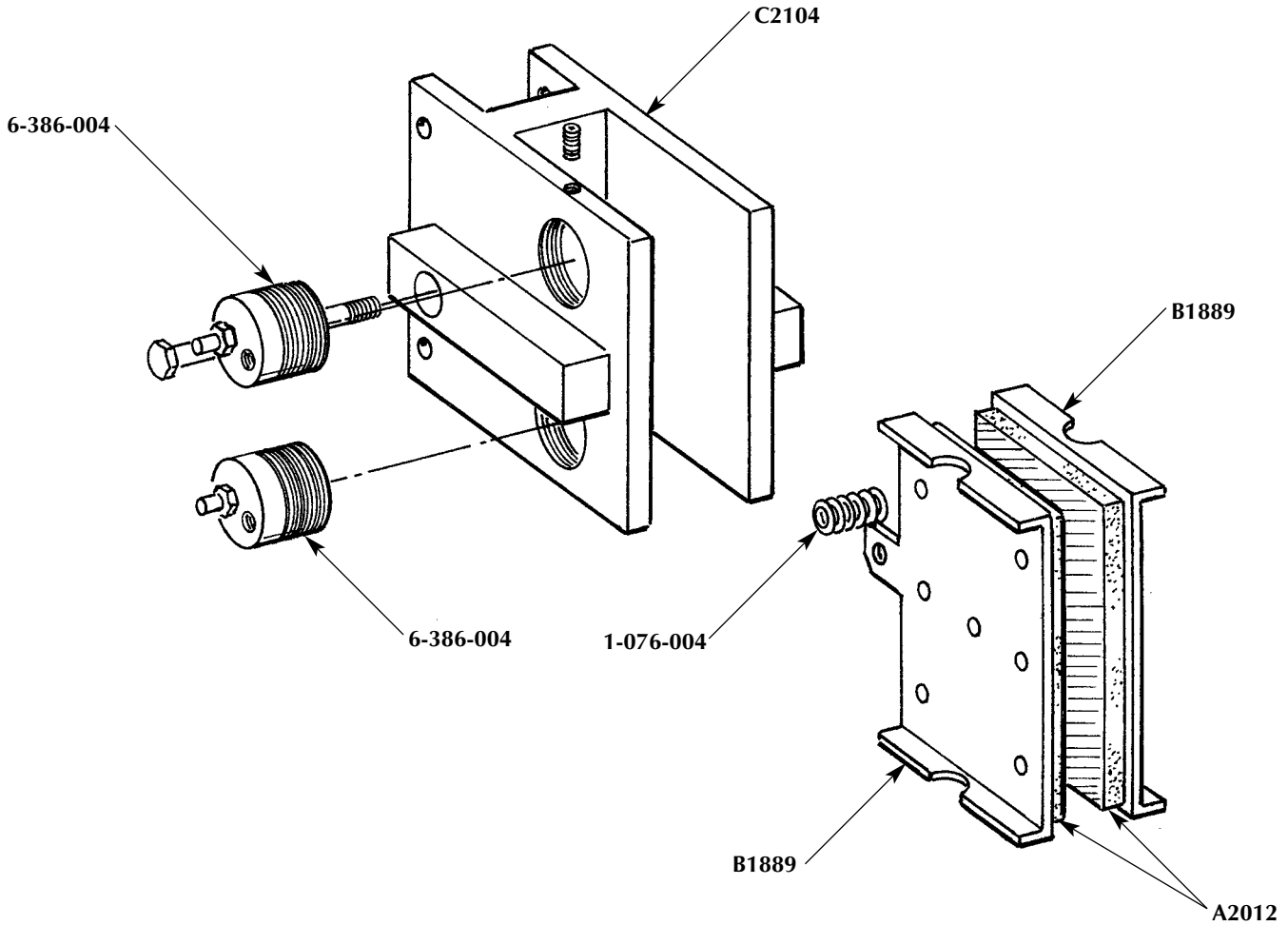

Part #	Description	Qty.
1-076-004	Return Spring, 2"	2
6-386-004	Actuator Piston	4
A2012	Brake Pad with Rivots	4
B1889	Brake Pad Mounting Plates	4
C2104	Caliper Body	2

CONDUCTOR KEEPER ASSEMBLY

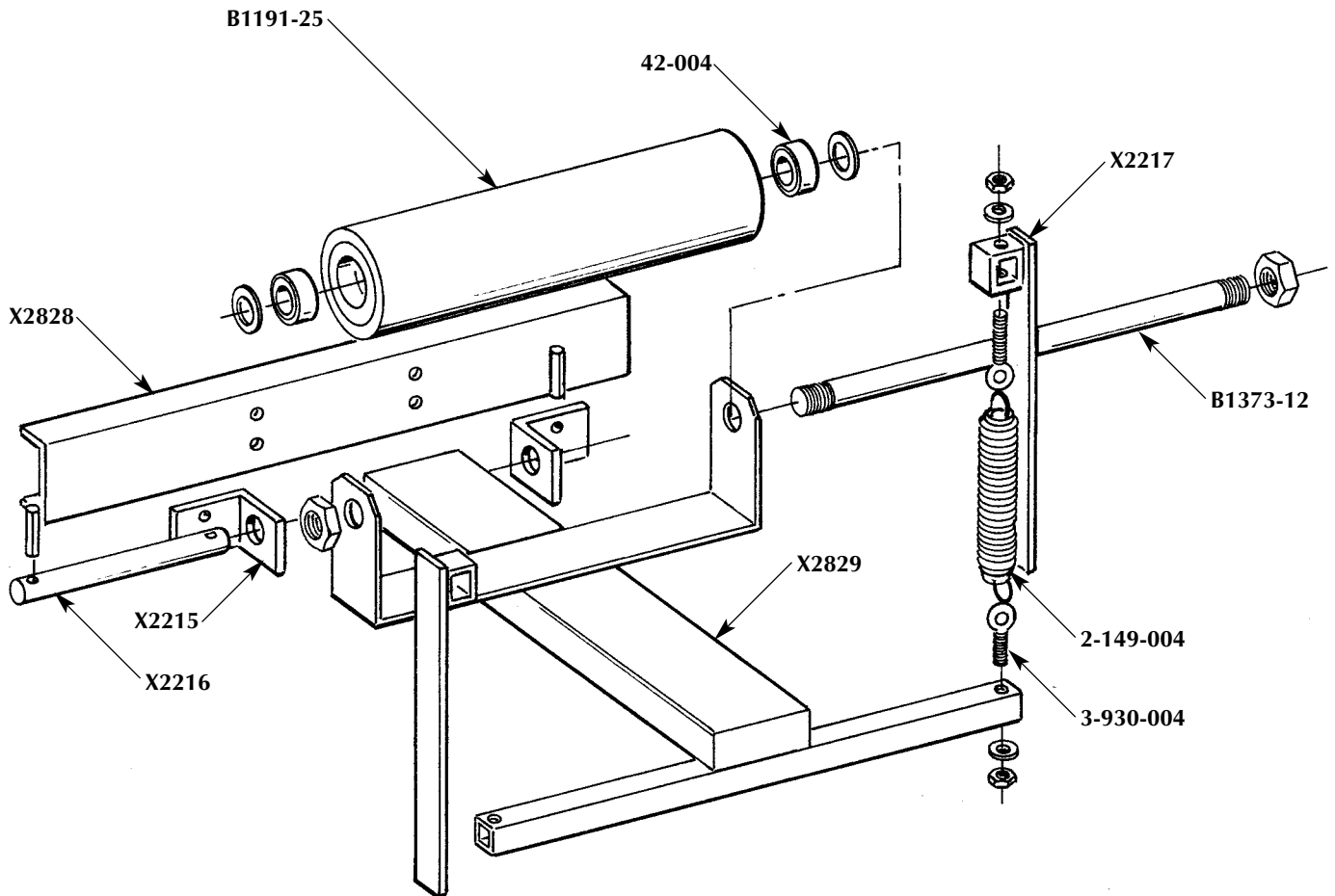

Part #	Description	Qty.
2-149-004	Pull Spring	2
3-390-004	Eye Bolt	4
42-004	Bearing	2
B1191-25	Roller, Urethane Coated	1
B1373-12	Shaft	1
X2215	Mounting Angle	2
X2216	Pivot Shaft	1
X2217	Spring Bracket Weldment	2
X2828	Mounting Channel	1
X2829	Frame Weldment	1

Section 5 • PARTS

FAIRLEAD ROLLER ASSEMBLY

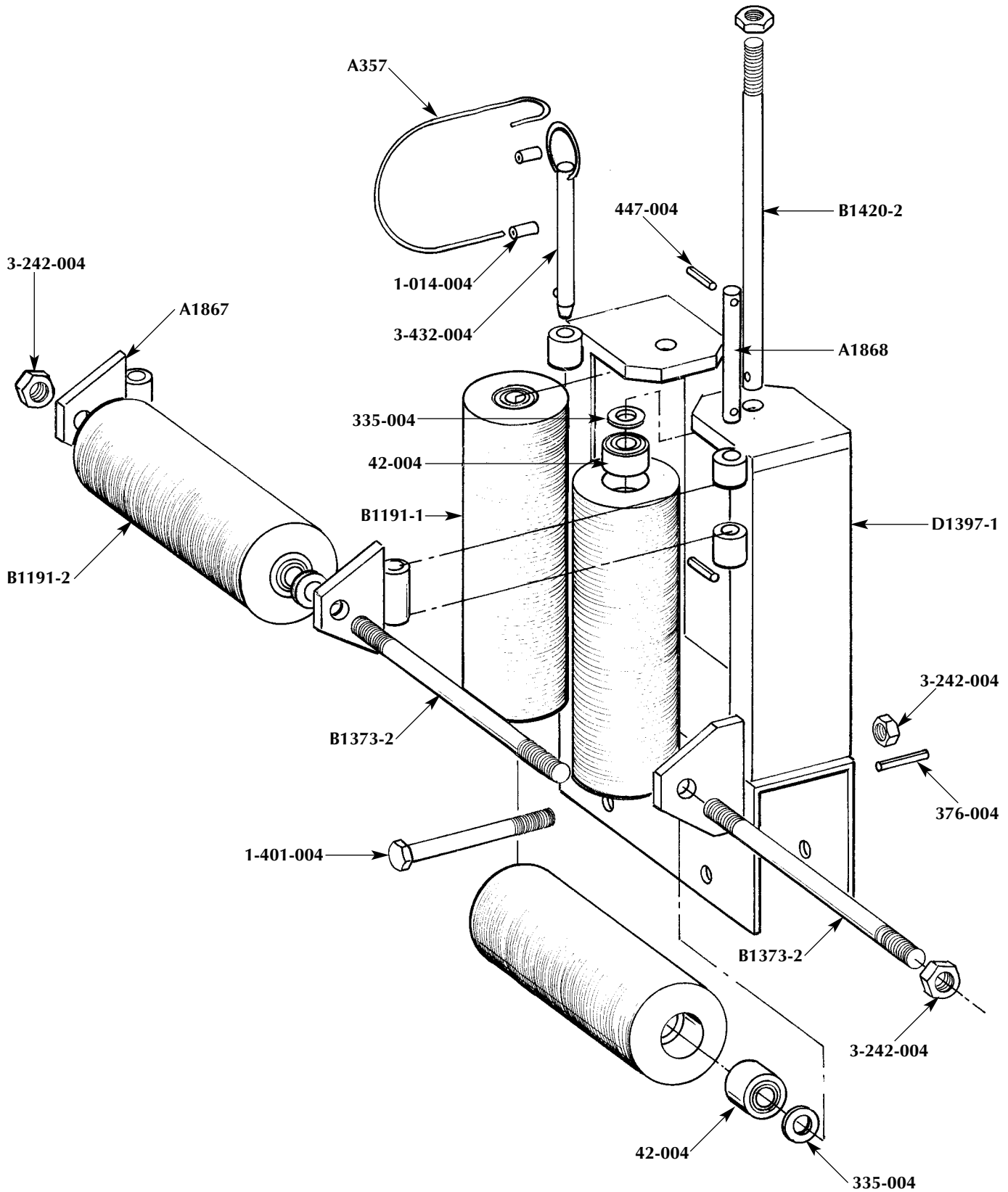

Section 5 • PARTS

REEL SHAFT ASSEMBLY

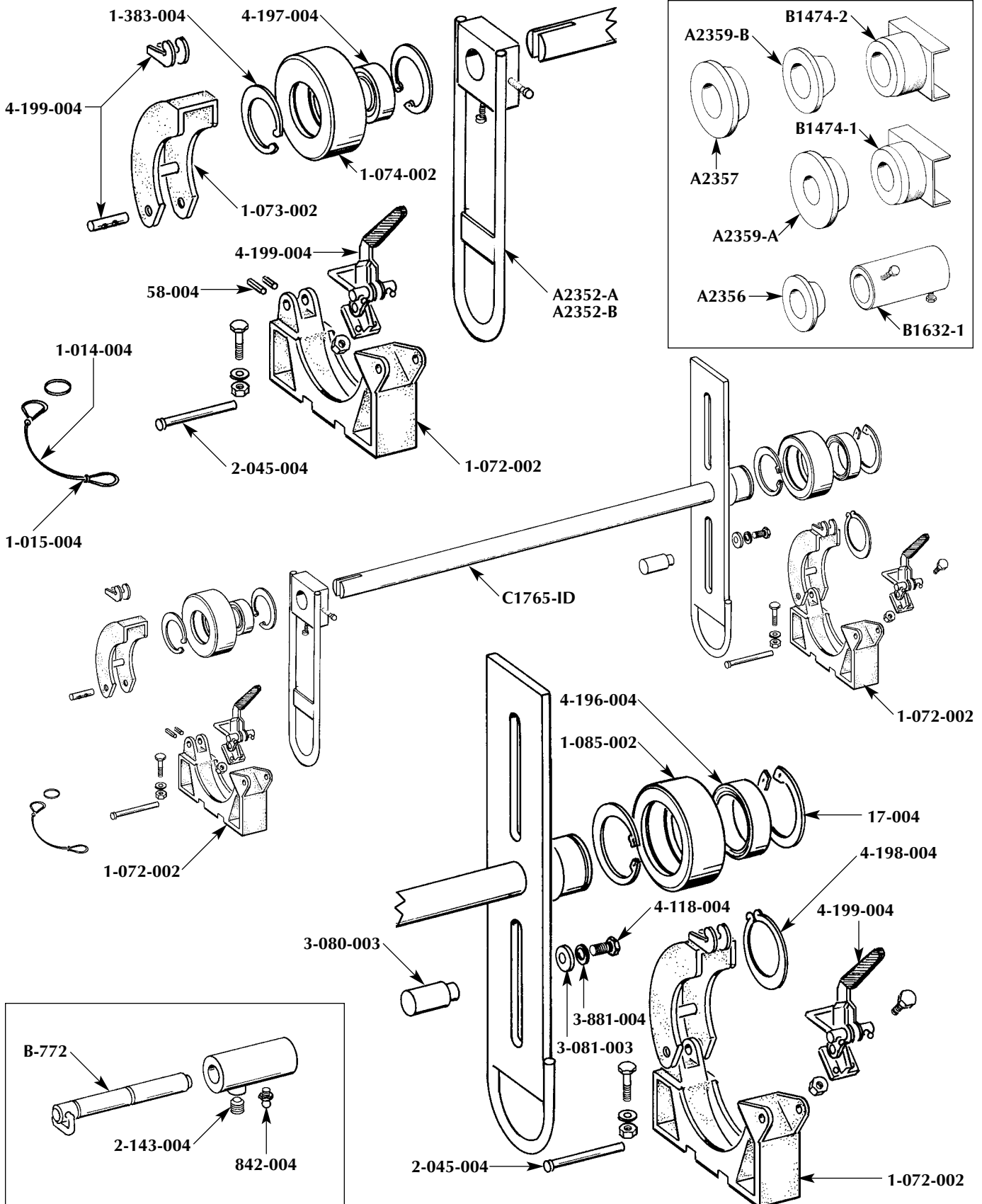



Section 5 • PARTS

REEL SHAFT ASSEMBLY

Part #	Description	Qty.
17-004	Snap Ring, Internal	2
1-014-004	Cord, $\frac{3}{32}$ Aircraft	2
1-015-004	Sleeve, Nicropress	4
1-072-002	Pillow Block Base	1
1-073-002	Pillow Block Cap	2
1-074-002	Pillow Block Housing	1
1-085-002	Pillow Block Housing	1
1-086-002	Pillow Block Base	1
1-383-004	Snap Ring, Internal	2
2-045-004	Pin, Detent $\frac{3}{8}$ "	2
2-143-004	Plunger, Stubby	4
3-080-003	Locking Dog	2
3-081-003	Washer	2
3-881-004	Washer, Lock $\frac{5}{8}$ "	2
4-118-004	Bolt, HHCS, $\frac{5}{8}$ " x $1\frac{1}{2}$ "	2
4-196-004	Bearing, Ball	1
4-197-004	Bearing, Ball	1
4-198-004	Snap Ring, Internal	1
4-199-004	Latch, Bearing Cap	2
4-670-004	Set Screw	3
58-004	Roll Pin	4
842-004	Fitting, Grease	4
A2352-A	Lifting Collar, $2\frac{5}{8}$ "	1
A2352-B	Lifting Collar, 2"	1
A2356	Tapered Cone, $2\frac{5}{8}$ " Shaft, 3" Arbor	1
A2357	Tapered Cone, 3" Shaft, 4" Arbor	1
A2359-A	Tapered Cone, $2\frac{5}{8}$ " Shaft, 5" Arbor	1
A2359-B	Tapered Cone, 3" Shaft, 5" Arbor	1
B1474-1	Reel Shaft Adapter, $2\frac{5}{8}$ " Shaft, 5" Arbor	1
B1474-2	Reel Shaft Adapter, 3" Shaft, 5" Arbor	1
B1632-1	Reel Shaft Spacer	1
B-772	Pin, Stop $1\frac{1}{8}$ "	4
C1765-ID	Reel Shaft and Drive Bar Weldment	1

Section 5 • PARTS

BED ROLLER ASSEMBLY

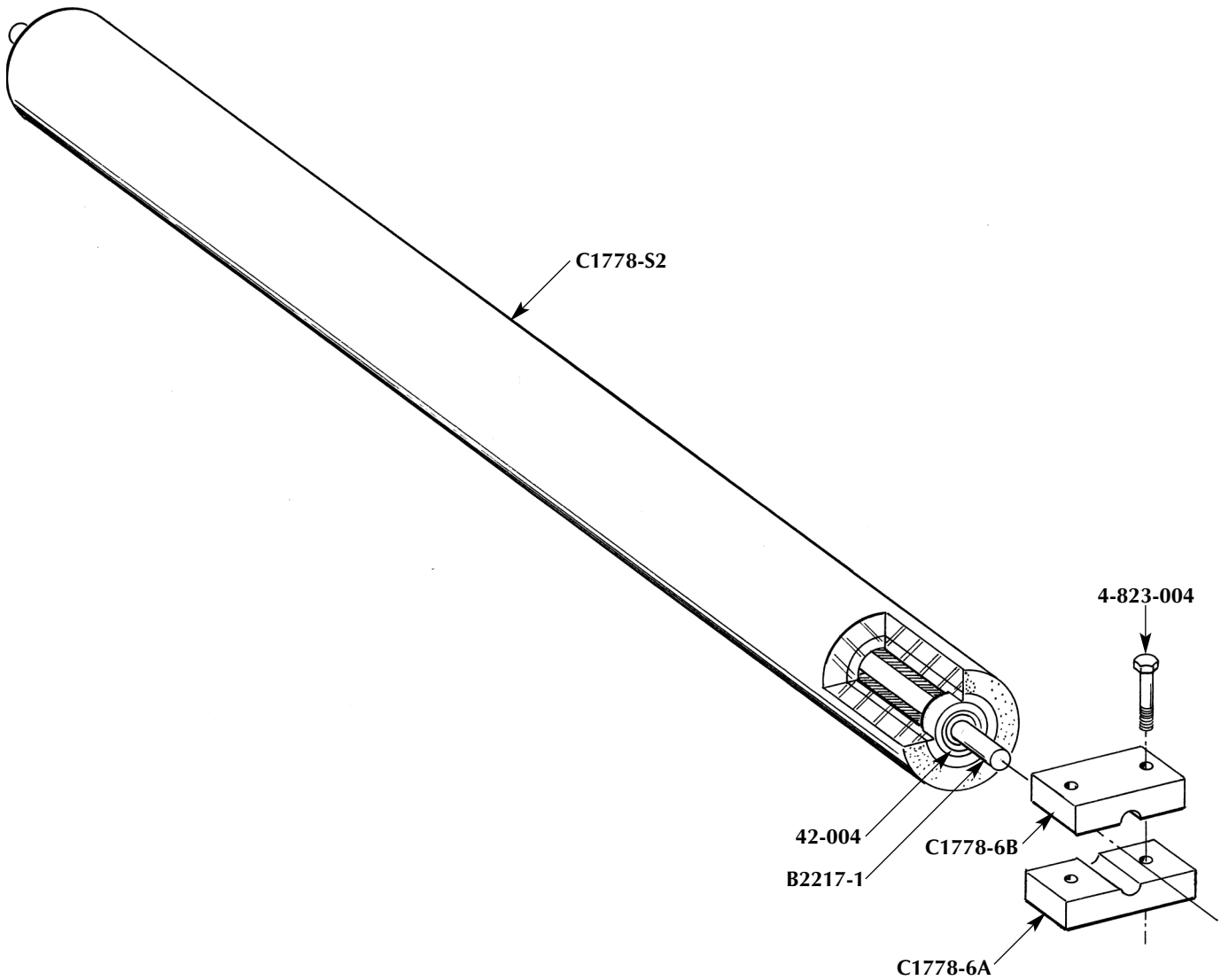

Part #	Description	Qty.
4-832-004	Bolt	4
42-004	Bearing	2
B2217-1	Roller Shaft	1
C1778-6A	Roller Mount, Lower	2
C1778-6B	Roller Mount, Upper	2
C1778-S2	Urethane Bed Roller	1

16" PAYOUT BRAKE ASSEMBLY (CURRENT PRODUCTION)

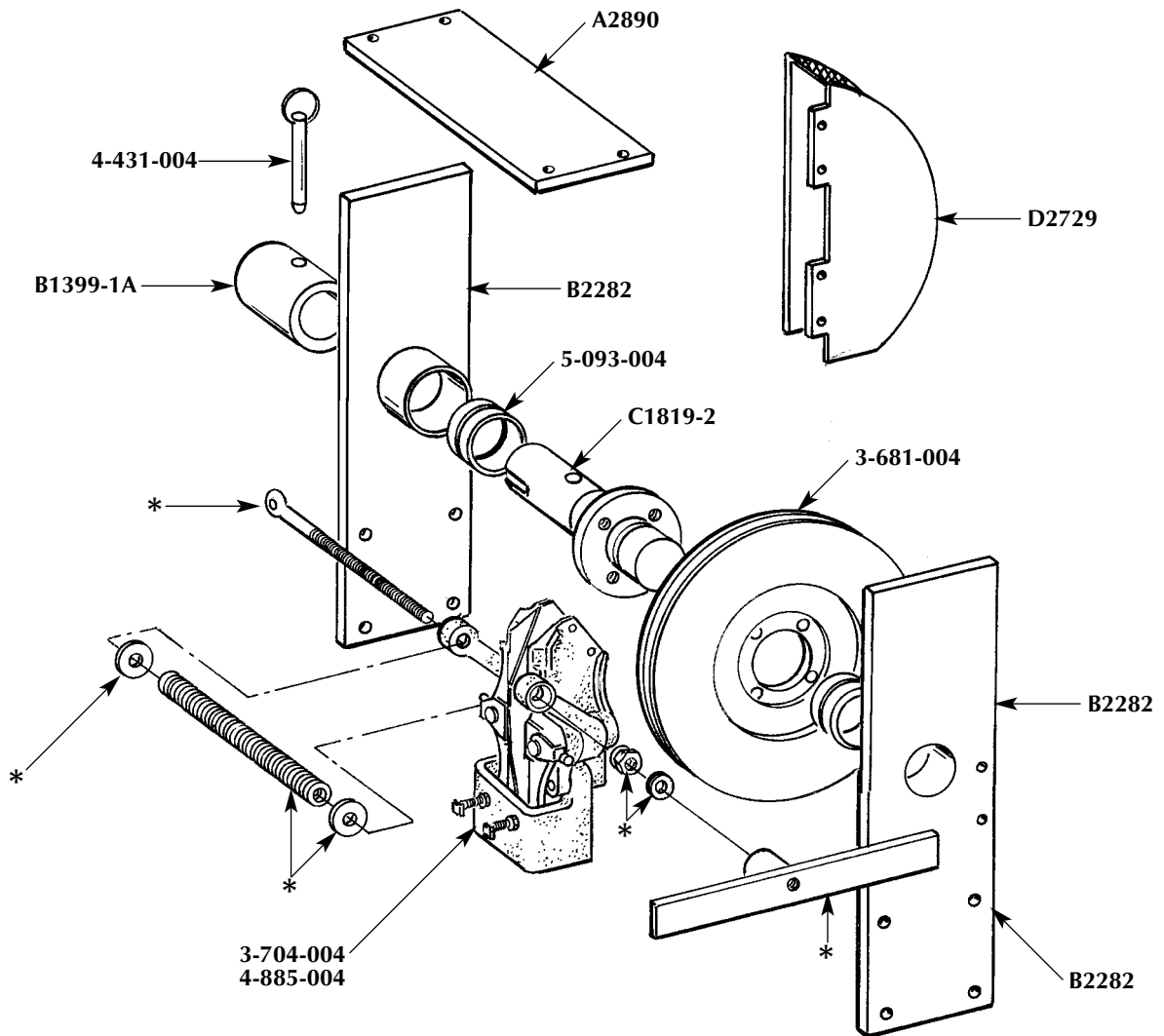

Part #	Description	Qty.
3-681-004	16" Ventilated Disc	1
3-704-004	16" Caliper Assembly	1
4-431-004	Detent Pin 7/8" – 4.3	1
4-885-004	Replacement Pads – Set of Two	1
5-093-004	Bronze Bushing A1548	2
A2890	Top Mounting Plate	1
B1399-1A	Brake Coupling	1
B2282	Side Frame	2
C1819-2	POB Shaft	1
D2729	Guard	1
*	T-Handle Assembly	1

Section 5 • PARTS

HYDRAULIC PAYOUT BRAKE ASSEMBLY (OPTIONAL)

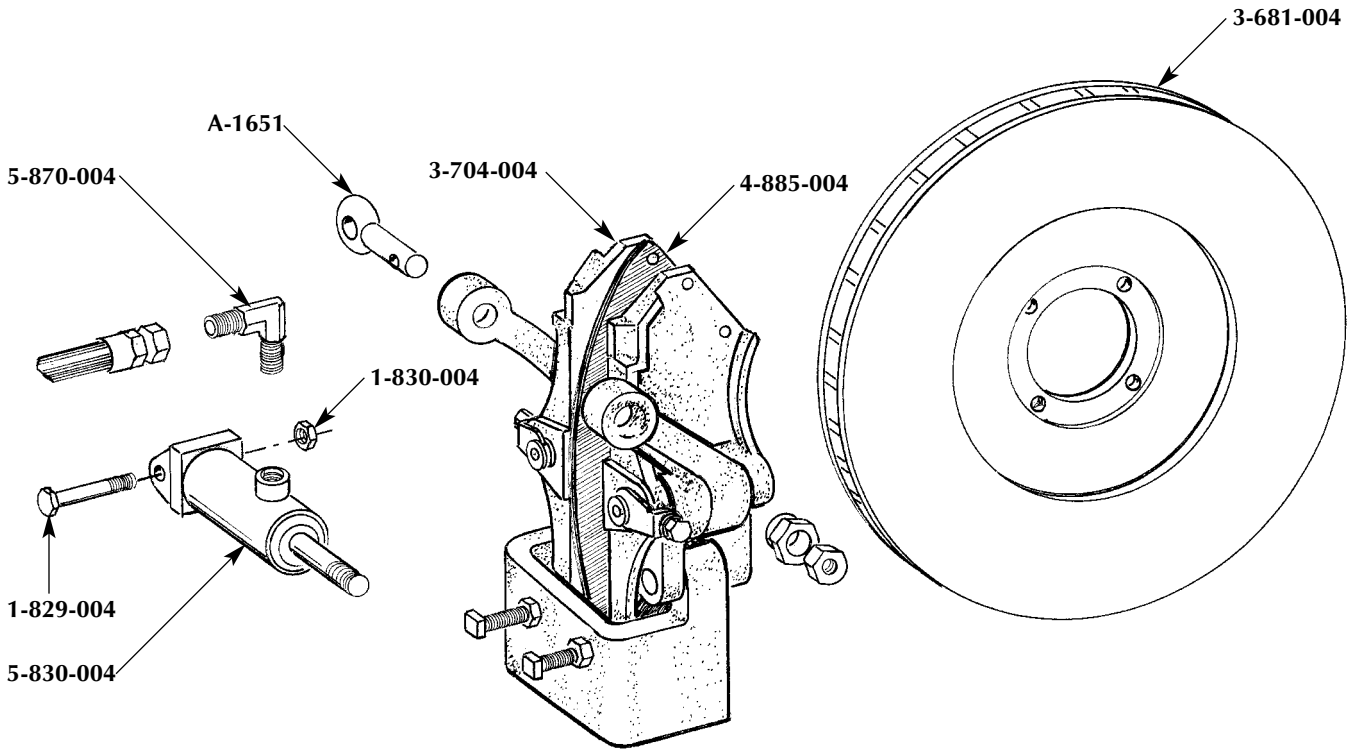

Part #	Description	Qty.
1-829-004	Hex Head Capscrew	1
1-830-004	Nut	1
3-681-004	Brake Disc, Bronze, 16" Diameter	1
3-704-004	Caliper, Brake	1
4-885-004	Pad, Brake with Rivets	2
5-870-004	#2MP – #2MJ 90°	1
A-1651	Rod, Cylinder Mount	1

SPIDER REWIND CONTROLS (OPTIONAL)

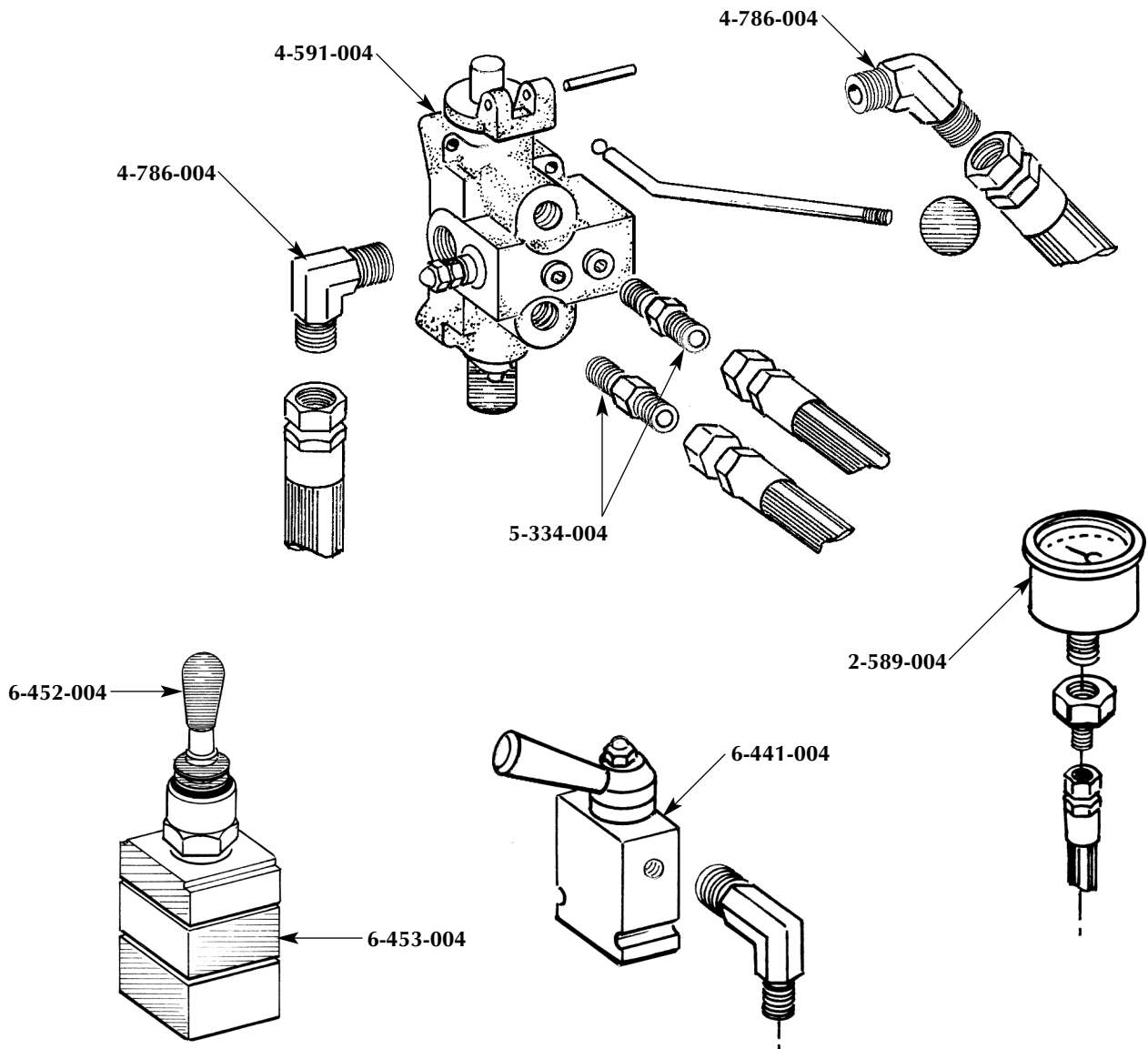

Part #	Description	Qty.
2-589-004	Pressure Gauge – 5,000 PSI	1
4-591-004	Valve, 4 Way	1
4-786-004	1/2" to 3/4" 90° Hydraulic Fitting	1
4-786-004	1/2" to 3/4" 45° Hydraulic Fitting	1
5-334-004	1/2" Hydraulic Fitting 90°	2
6-441-004	Selector Valve / Brake	1
6-452-004	Toggle Switch	1
6-453-004	Contact Block Assembly	

Section 5 • PARTS

RETRIEVER DRIVE ASSEMBLY – PILOT LINE SYSTEM (OPTIONAL)

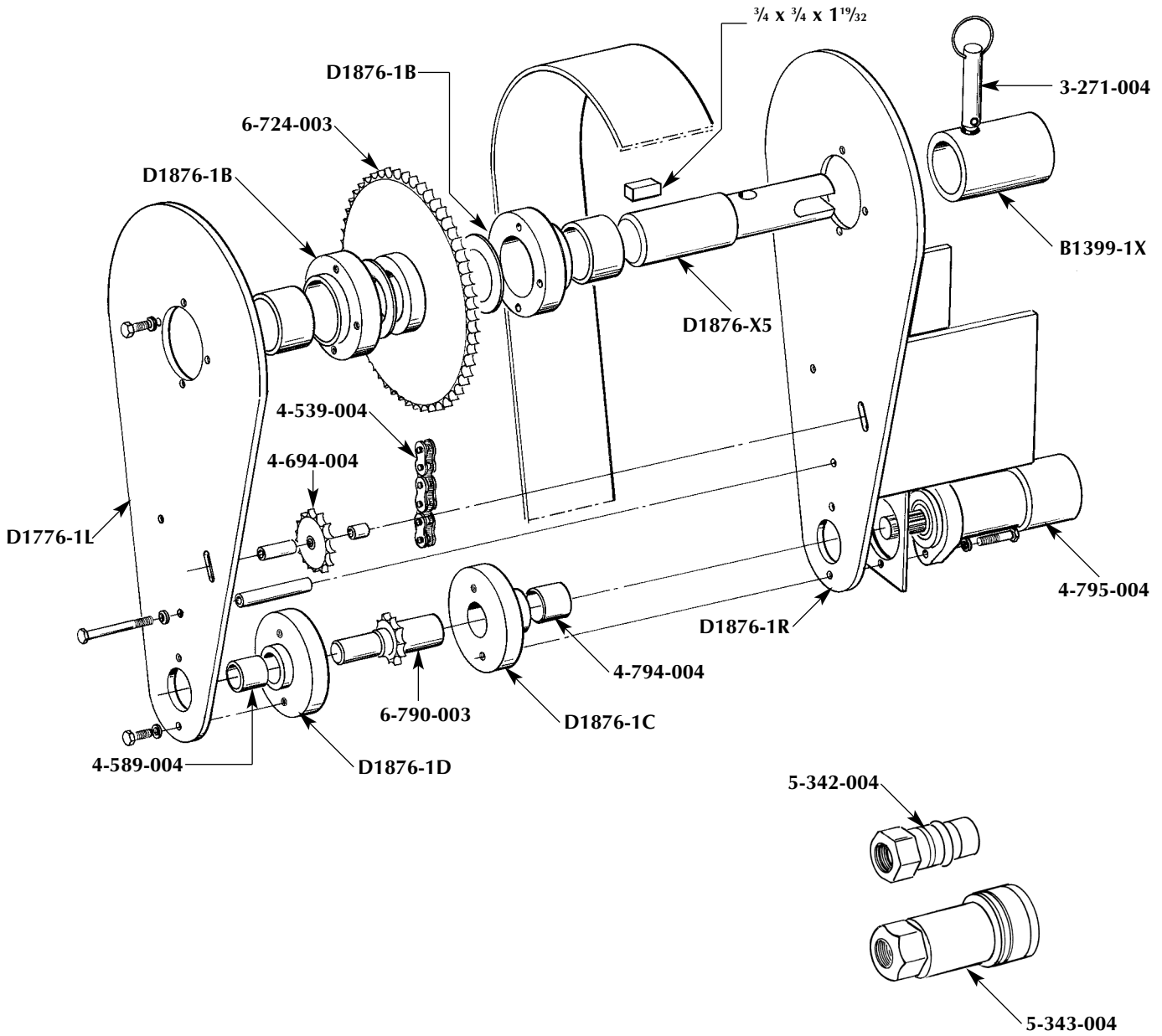



Section 5 • PARTS

RETRIEVER DRIVE ASSEMBLY – PILOT LINE SYSTEM (OPTIONAL)

Part #	Description	Qty.
3-271-004	Detent Pin	1
4-539-004	Drive Chain	1
4-589-004	Bushing, Bronze, 1 ⁵ / ₈ " x 1 ³ / ₈ " x 1 ¹ / ₂ "	1
4-694-004	Idler Sprocket	1
4-754-004	Bushing, Bronze, 1 ¹ / ₂ " x 1" x 1 ¹ / ₄ "	3
4-794-004	Bushing, Bronze, 1 ⁷ / ₈ " x 1 ⁵ / ₈ " x 1 ¹ / ₂ "	3
4-795-004	Motor, Hydraulic	1
5-342-004	Quick Connect, 3/8" Male	1
5-343-004	Quick Connect, 3/8" Female	1
6-724-003	Sprocket, Driven	1
6-790-004	Sprocket Drive	1
B1399-1X	Coupler	1
D1776-1L	Side Plate, Left	1
D1786-1R	Side Plate, Right	1
D1876-1B	Bearing Block, Upper	2
D1876-1C	Bearing Block, Lower Right	1
D1876-1D	Bearing Block, Lower Left	1
D1876-X5	Drive Shaft	1

Section 5 • PARTS

SPIDER REWIND DRIVE ASSEMBLY – PILOT LINE SYSTEM (OPTIONAL)

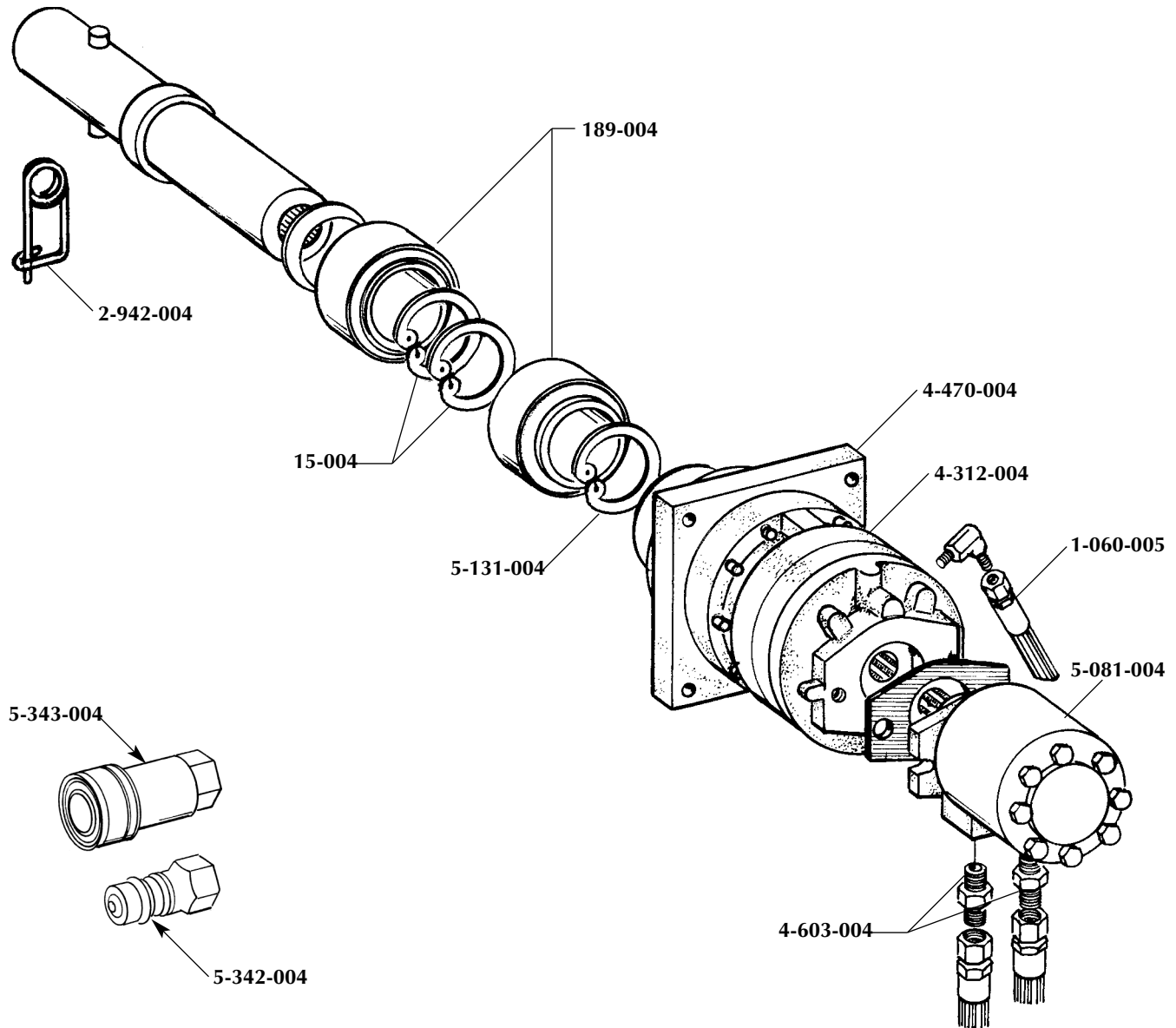

Part #	Description	Qty.
15-004	Snap Ring, #5000-433	2
189-004	Bearing, Ball #212KO	2
2-942-004	Pin, Safety Locking	1
4-312-004	Brake, Spring Applied	1
4-470-004	Gear Box S07A46604	1
4-603-004	Adapter, 10MB-08MJIC	2
5-081-004	Motor, Hydraulic Drive	1
5-131-004	Snap Ring #5100-0237	2
5-342-004	Quick Connect, $\frac{3}{8}$ " Male	1
5-343-004	Quick Connect, $\frac{3}{8}$ " Female	1

SPIDER GUIDE ROLLER ASSEMBLY – PILOT LINE SYSTEM (OPTIONAL)

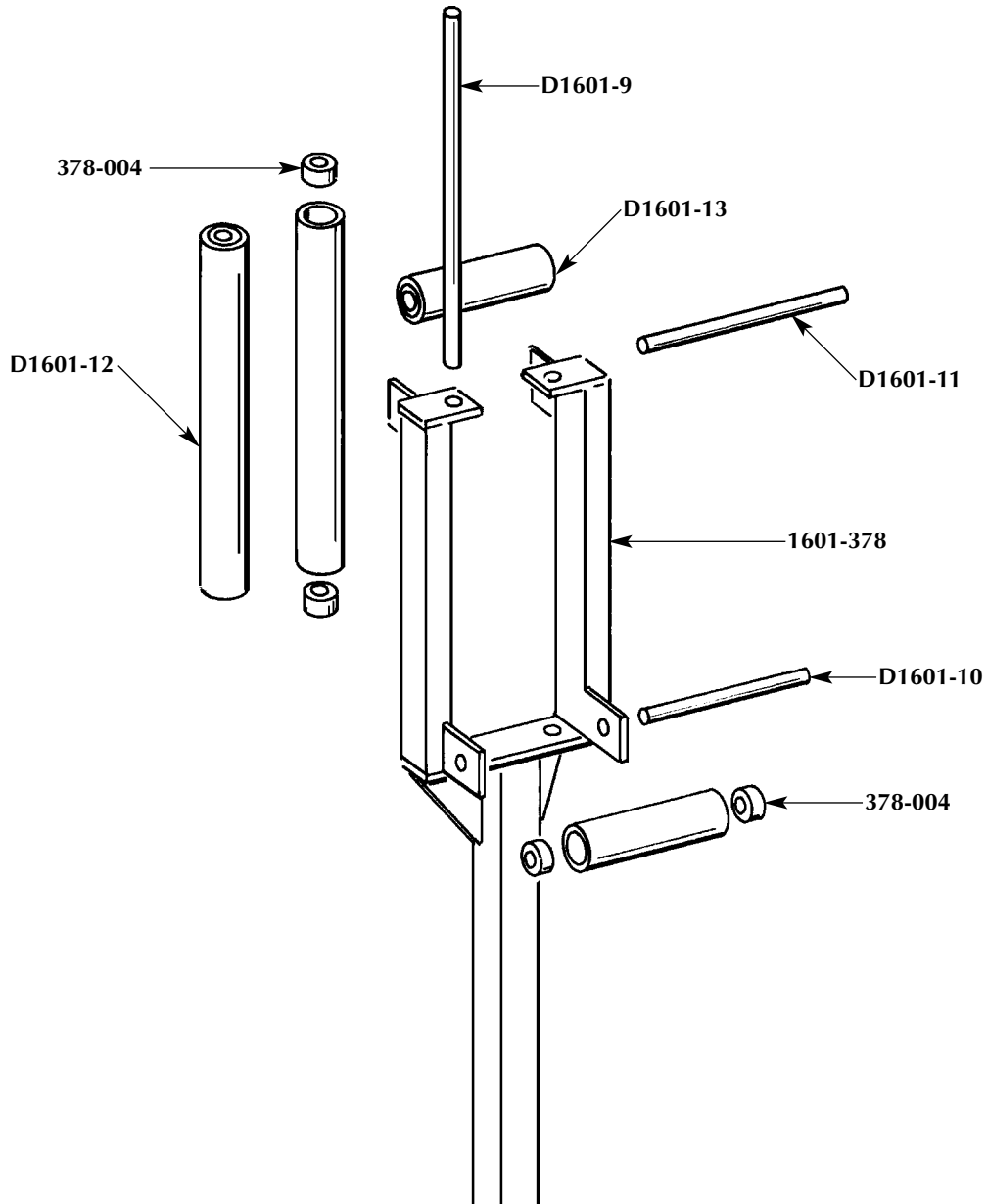

Part #	Description	Qty.
C1723-8	Bar, 1" Diameter x 6 ⁵ / ₈ " Long C.R.	1
D1601-9	Bar, ⁵ / ₈ " Diameter x 15 ³ / ₁₆ " Long	2
D1601-10	Bar, ⁵ / ₈ " Diameter x 7 ³ / ₈ " Long	1
D1601-11	Bar, ⁵ / ₈ " Diameter x 7 ³ / ₄ " Long	1
D1601-12	Alum, 2" Diameter x 14 ¹ / ₂ " Long	2
D1601-13	Alum, 2" Diameter x 6 ¹ / ₄ " Long	2
378-004	Ball Bearing	8

Section 5 • PARTS

HYDRAULIC JACK ASSEMBLY (OPTIONAL)

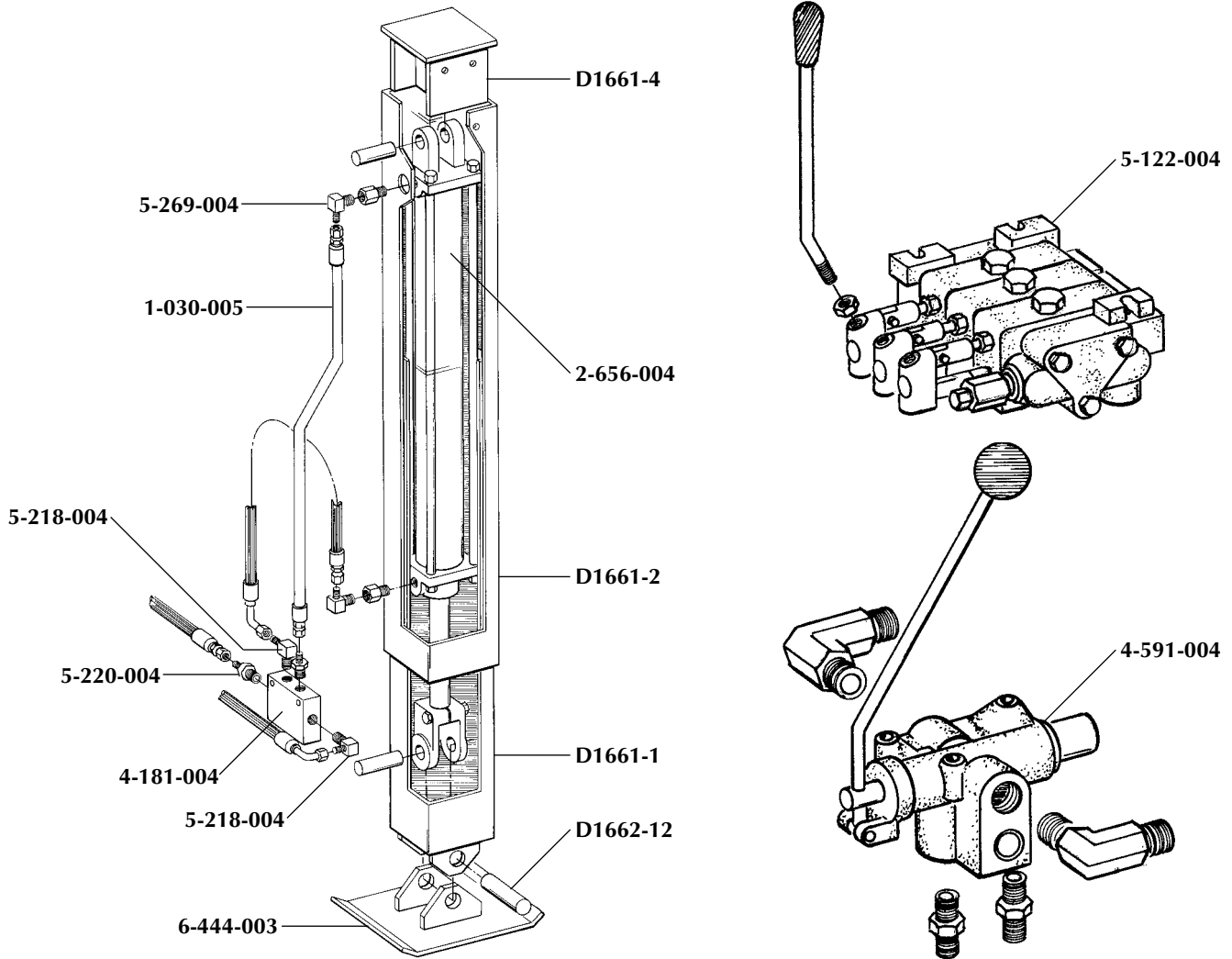

Part #	Description	Qty.
1-030-004	3/8" Hose	1
2-656-004	Cylinder, Jack	1
4-181-004	Valve, Counterbalance	1
4-591-004	Jack Control Valve (for units with hydraulic front jack only)	1
5-122-004	Jack Control Valve (for units with front and rear hydraulic jacks)	1
5-218-004	#6MP - #6MJIC - 90°	2
5-220-004	#6MP - #6MJIC	1
5-269-004	#8MP - #6MJIC - 90°	2
6-444-003	Jack, Foot Pad Weldment	1
D1661-1	Jack Tube, Inside	1
D1661-2	Jack Tube, Outside	1
D1661-4	Jack, Cylinder Mount	1
D1662-12	Pin, Jack Foot Pad	1

OPERATING CONTROLS

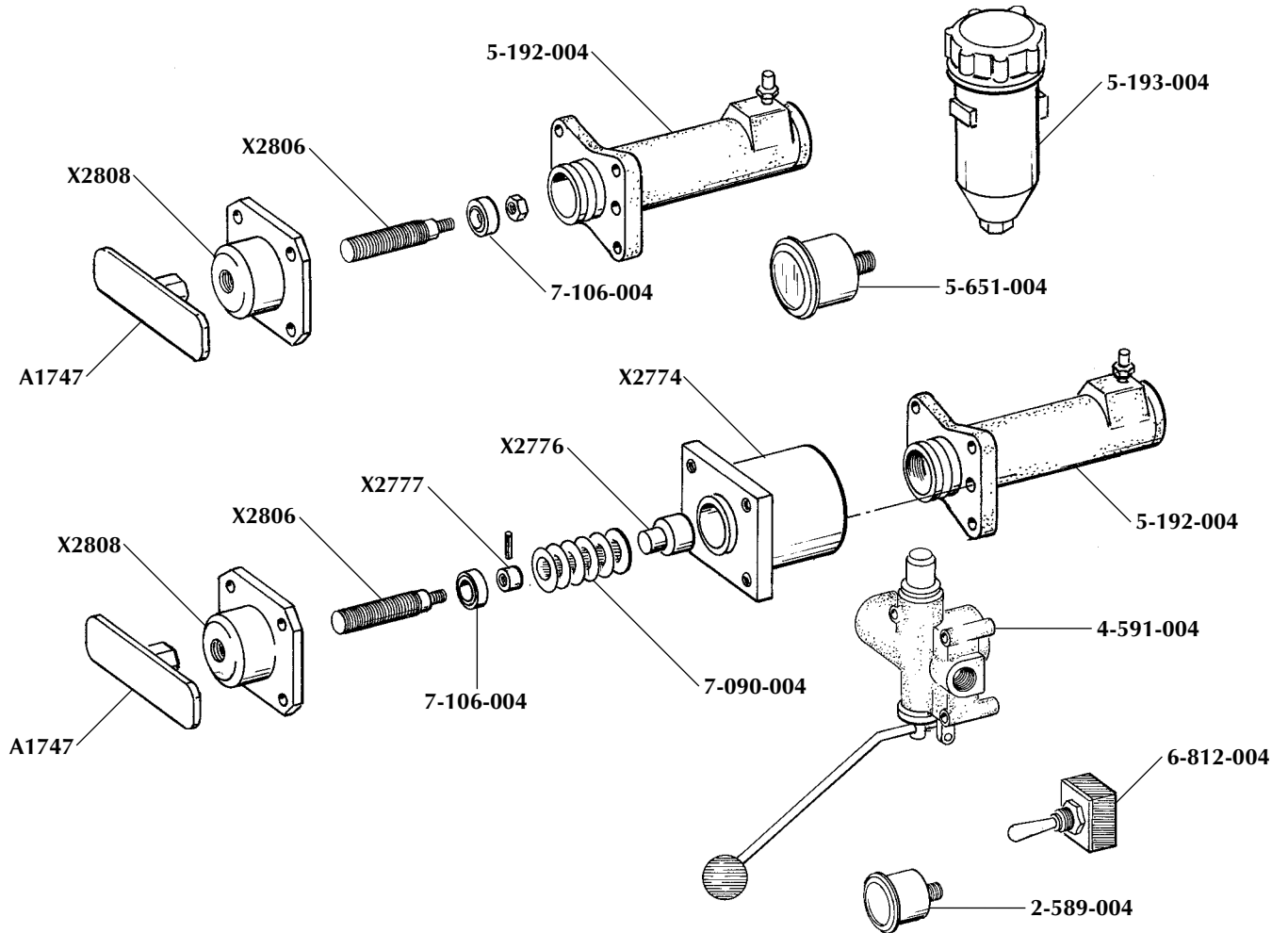

Part #	Description	Qty.
2-589-004	Pressure Gauge – 5,000 PSI	1
4-591-004	Control Valve (Retriever Control)	1
5-192-004	Master Cylinder (Brake Actuator)	1
5-193-004	Brake Fluid Reservoir	1
5-651-004	Pressure Gauge – 200 PSI	1
6-812-004	Toggle Switch	1
7-090-004	Spring	1
7-106-004	Bearing	1
A1747	Tension Control Handle	1
X2774	Spacer	1
X2776	Plunger	1
X2777	Nut	1
X2806	Actuator Rod	1
X2808	Master Cylinder Mount	1

Section 5 • PARTS

POWER PACK ENGINE & PUMP ASSEMBLY (OPTIONAL)

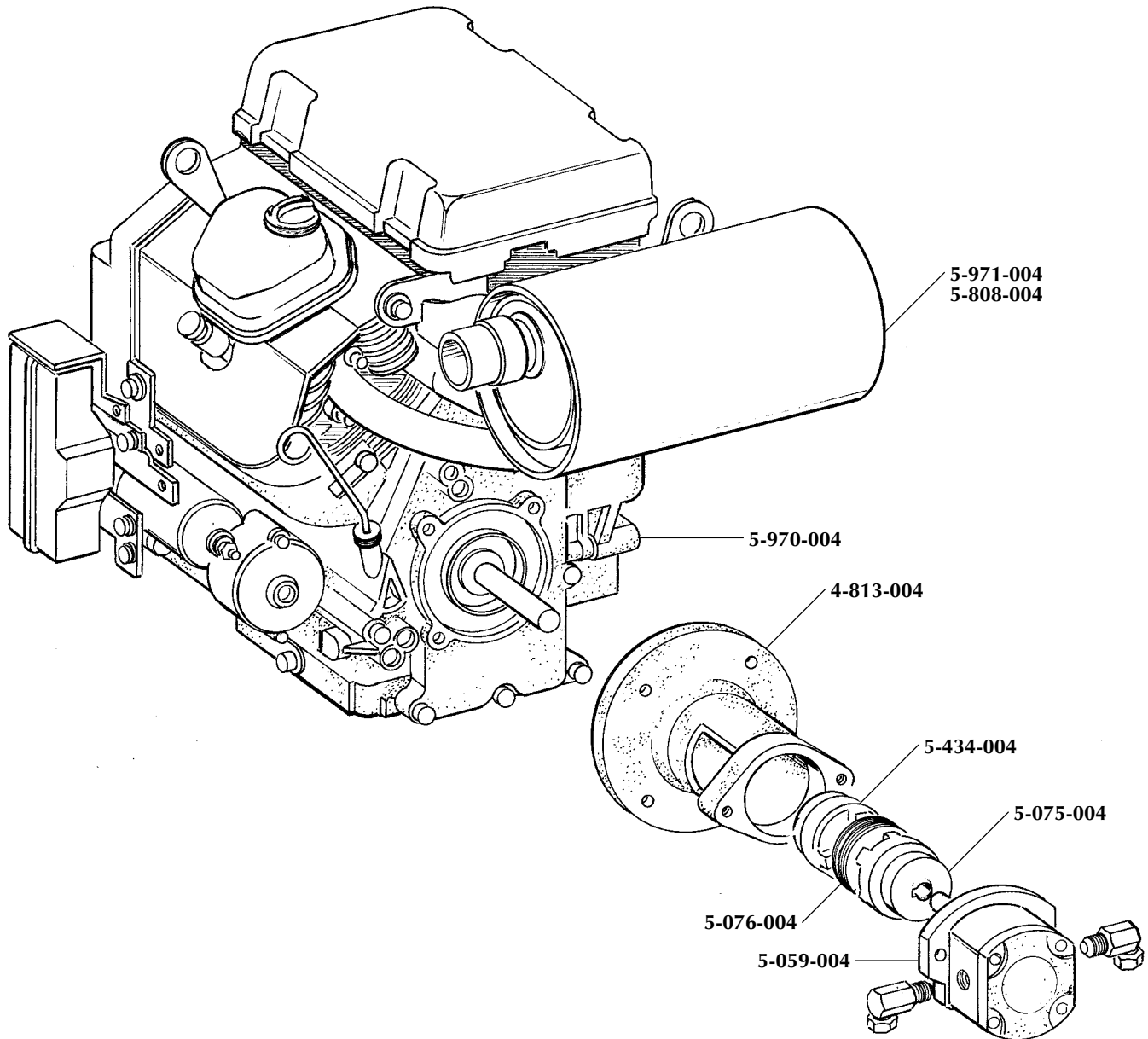

Part #	Description	Qty.
4-813-004	Pump to Engine Mount	1
5-059-004	Hydraulic Pump	1
5-075-004	Coupling, $\frac{5}{8}$ " Bore	1
5-076-004	Flexible Insert	1
5-434-004	Coupling, 1" Bore	1
5-808-004	Exhaust Deflector	1
5-970-004	Honda 18 HP Engine	1
5-971-004	Honda Muffler Kit	1

POWER PACK COMPONENTS (OPTIONAL)

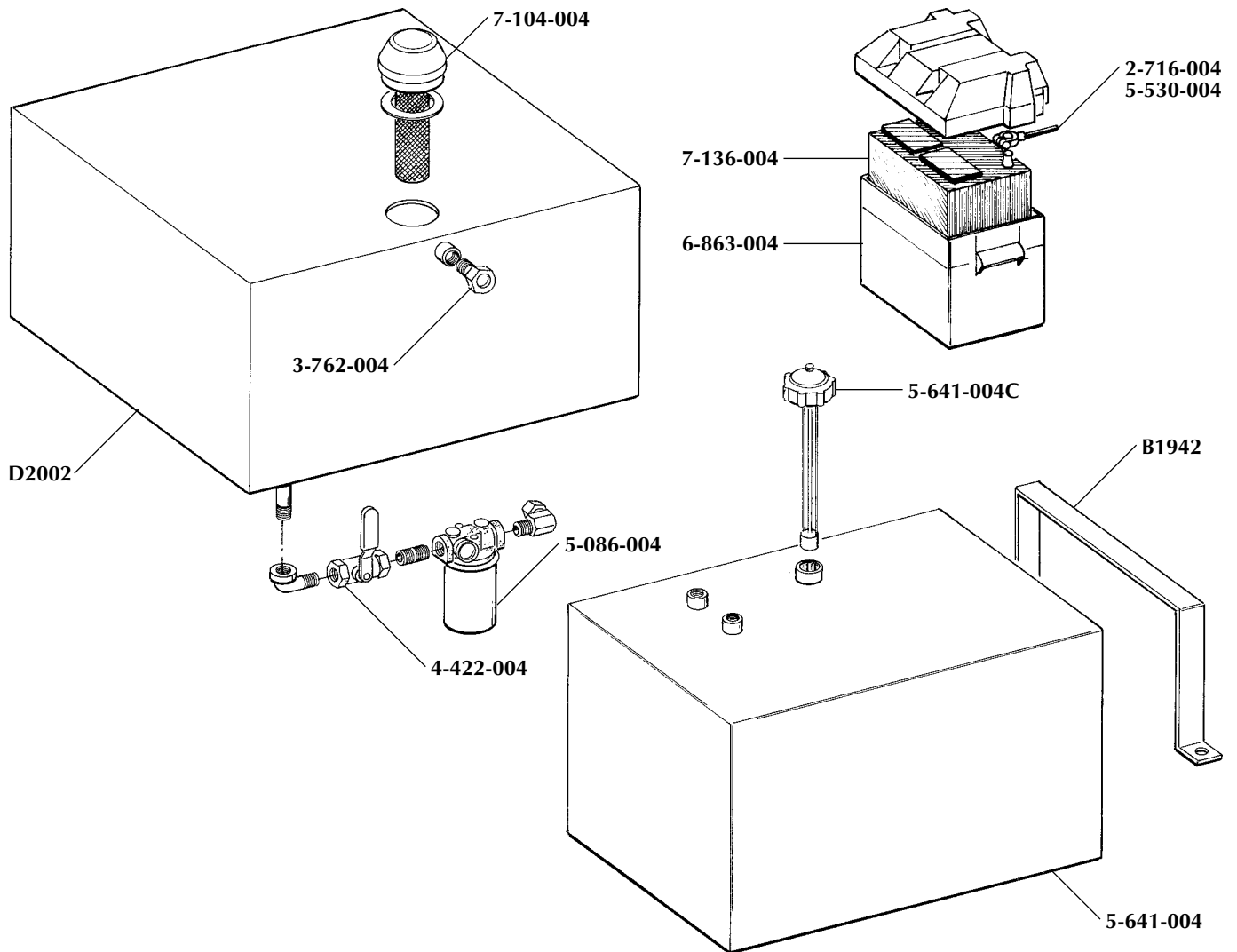

Part #	Description	Qty.
2-716-004	Battery Cable, Red +	1
3-762-004	Site Gauge	1
4-422-004	Ball Valve	1
5-086-004	Hydraulic Filter, 10 micron	1
5-530-004	Battery Cable, Black -	1
5-641-004	Fuel Tank, 14 Gallon	1
5-641-004-C	Filler Cap and Fuel Gauge	1
6-863-004	Solar Panel	1
7-104-004	Filler Cap Assembly, Oil Tank	1
7-136-004	Battery	1
B1942	Fuel Tank Strap	2
D2002	Hydraulic Tank	1

Section 5 • PARTS

TRAILER COMPONENTS

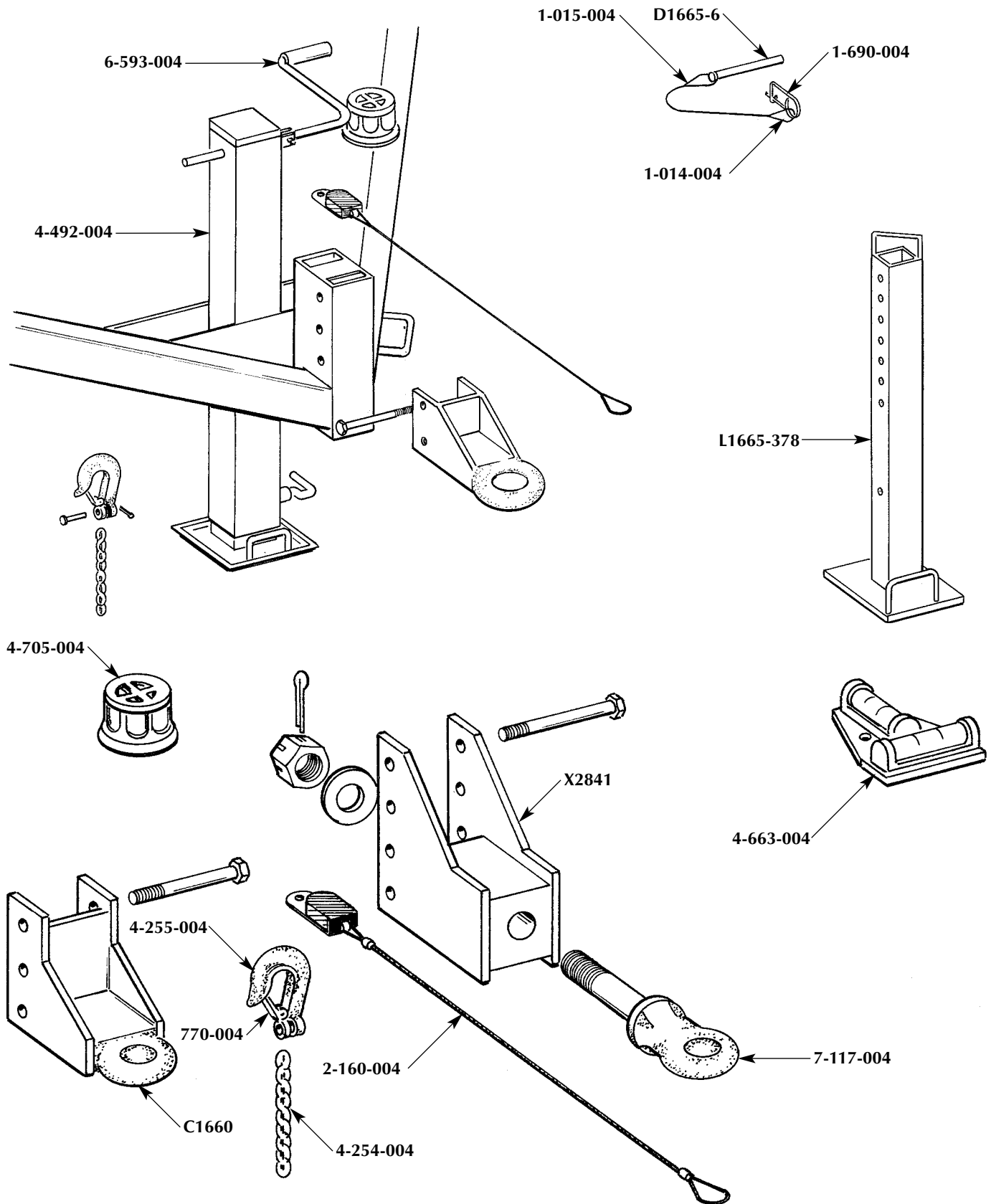

Section 5 • PARTS

OPERATOR'S SEAT & MISCELLANEOUS

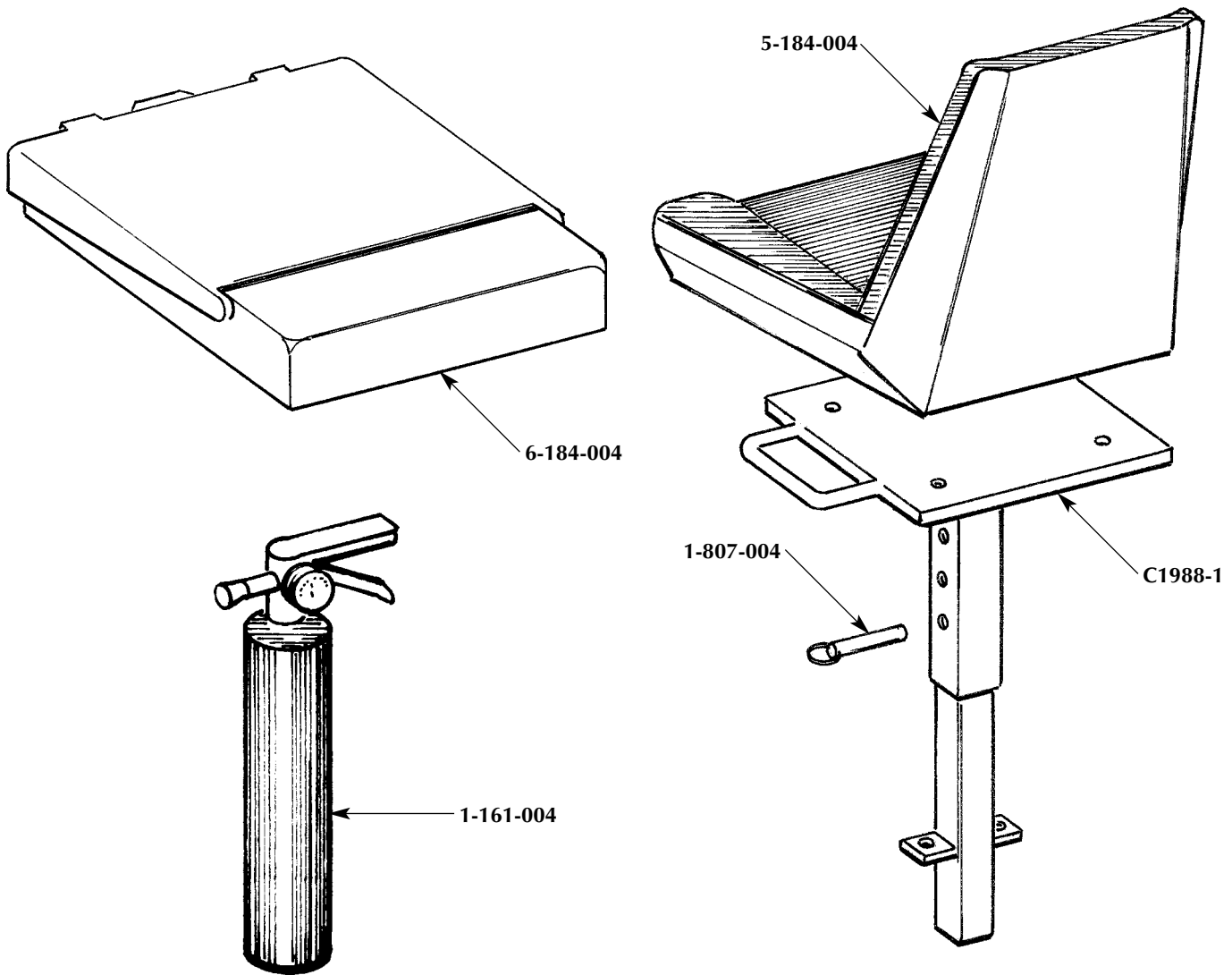

Part #	Description	Qty.
1-161-004	Fire Extinguisher	1
1-807-004	Detent Pin	1
5-184-004	Seat, Adjustable High Back	1
6-184-004	Manual Holder	1
C1988-1	Seat Stand	1

SHERMAN & REILLY, INC.

P.O. Box 11267 • 400 West 33rd Street
Chattanooga, TN 37401 USA

Phone 423•756•5300

Fax No. 423•756•2948

Toll-Free 800•251•7780

Web Site www.sherman-reilly.com